

MAXILIFT

Hydraulic Passenger Lift Range

Edition 15.11.11

MAXILIFT

Stannah

Hydraulic Passenger Lift Range

<i>Section</i>	TABLE OF CONTENTS	<i>Reference</i>	<i>Date</i>
0	Contents—page 1 of 2 Contents—page 2 of 2	Contents-0 Contents-0-1	24/02/11 24/02/11
1	Section 1 Contents Models & Door Arrangements - Maxilift Reduced Headroom Range - Door Options - 6-8 Persons Maxilift Range - Door Options - 6-16 Persons Selection Process Maxilift Philosophy Acceleration Curve	Contents-1 1-1 1-5 1-6 1-7 1-8 1-9	24/02/11 24/02/11 24/02/11 17/06/10 17/06/10 24/02/11 17/06/10
2	Section 2 Contents Model specifications - General Model specifications - Reduced Headroom range Model specifications - Maxilift range <i>Withdrawn 14/11/05</i>	Contents-2 2-1 2-2 2-3 2-9	24/02/11 24/02/11 24/02/11 24/02/11 <i>Obsolete</i>
3	<i>Section 3 - Withdrawn 04/01/02</i>		<i>Obsolete</i>
4	<i>Section 4 - Withdrawn 25/05/04</i>		<i>Obsolete</i>
5	<i>Section 5 - Withdrawn 25/05/04</i>		<i>Obsolete</i>
6	Section 6 Contents <i>Withdrawn 17/10/06</i> <i>Withdrawn 17/10/06</i> <i>Withdrawn 17/10/06</i> <i>Withdrawn 17/10/06</i> 6 Person - Architects Details 6 Person - Architects details - MRC	Contents-6 6-1 6-3 6-5 6-6 6-7 6-8	17/06/10 <i>Obsolete</i> <i>Obsolete</i> <i>Obsolete</i> <i>Obsolete</i> 15/11/11 17/06/10
7	Not Used		
8	Section 8 Contents <i>Withdrawn 17/10/06</i> <i>Withdrawn 17/10/06</i> <i>Withdrawn 17/10/06</i> <i>Withdrawn 17/10/06</i> <i>Withdrawn 17/10/06</i> <i>Withdrawn 17/10/06</i> 8 Person - Architects Details - MRLi 8 Person - Architects Details - MRLi - Alternative Controller Locations 8 Person - Architects Details 8 Person - Architects Details - MRC	Contents-8 8-1 8-3 8-5 8-7 8-8 8-9 8-12-1 8-12-2 8-13 8-14	17/06/10 <i>Obsolete</i> <i>Obsolete</i> <i>Obsolete</i> <i>Obsolete</i> <i>Obsolete</i> <i>Obsolete</i> 24/02/11 17/06/10 24/02/11 17/06/10
9	Not Used		
10	Section 10 Contents 10 Person - Architects Details <i>Withdrawn 17/10/06</i> <i>Withdrawn 17/10/06</i> 10 Person - Architects Details - MRLi 10 Person - Architects Details - MRLi - Alternative Controller Locations 10 Person - Architects Details - MRC	Contents-10 10-1 10-3 10-4 10-6-1 10-6-2 10-7	17/06/10 17/06/10 <i>Obsolete</i> <i>Obsolete</i> 17/06/10 17/06/10 17/06/10
11 / 12	Not Used		

Contents-0
15/11/11

cont'd ...

MAXILIFT

Stannah

Hydraulic Passenger Lift Range

<i>Section</i>	TABLE OF CONTENTS	<i>Reference</i>	<i>Date</i>
13	Section 13 Contents	Contents-13	17/06/10
	13 Person - Architects details - Stretcher	13-1	17/06/10
	13 Person - Architects details - Square shape	13-2	17/06/10
	<i>Withdrawn 17/10/06</i>	13-4	<i>Obsolete</i>
	<i>Withdrawn 17/10/06</i>	13-5	<i>Obsolete</i>
	<i>Withdrawn 17/10/06</i>	13-6	<i>Obsolete</i>
	<i>Withdrawn 17/10/06</i>	13-7	<i>Obsolete</i>
	13 Person - Architects details - Stretcher - MRLi	13-10-1	17/06/10
	13 Person - Architects details - Stretcher - MRLi - Alternative Controller Locations	13-10-2	17/06/10
	13 Person - Architects details - Square shape - MRLi	13-11-1	17/06/10
	13 Person - Architects details - Square shape - MRLi - Alternative Controller Locations	13-11-2	17/06/10
	13 Person - Architects details - Stretcher - MRC	13-12	17/06/10
	13 Person - Architects details - Square shape - MRC	13-13	17/06/10
14 / 15	Not used		
16	Section 16 Contents	Contents-16	17/06/10
	16 Person - Architects details	16-1	17/06/10
	16 Person - Architects details - MRLi	16-2	17/06/10
	16 Person - Architects details - Alternate Controller Locations	16-3	17/06/10
	16 Person - Architects details - MRC	16-4	17/06/10
17/19	Not used		
20	Section 20 Contents	Contents-20	24/02/11
	Sales data sheets - Table of Contents - Page 1 of 2	20-D0	24/02/11
	Sales data sheets - Table of Contents - Page 2 of 2	20-D0-1	17/06/10
	Minimum pit depth	20-D1	17/06/10
	Minimum pit depth - MRLi	20-D1-1	17/06/10
	Headroom dimensions - Indirect	20-D2	24/02/11
	Headroom dimensions - Direct	20-D3	24/02/11
	Hydraulic Specifications - 6 Person Maxilift	20-D7	24/02/11
	Hydraulic Specifications - 8 Person Maxilift	20-D8	24/02/11
	Hydraulic Specifications - 10 Person Maxilift	20-D9	17/06/10
	Hydraulic Specifications - 13 Person Maxilift	20-D10	17/06/10
	Electrical Requirements by Electrical Contractor	20-D11	17/06/10
	Electrical Current Loadings and Fuse Ratings	20-D12	17/06/10
	Lift Pit Information - Pit Foothole Details	20-D13	17/06/10
	Lift Pit Information - WM Models Single Entrance Details	20-D14	17/06/10
	Lift Pit Information - WM Models Through Entrance Details	20-D15	17/06/10
	Landing Entrance Arrangement - Automatic Two Panel Side Opening	20-D17	17/06/10
	<i>Withdrawn</i>	20-D17-1	<i>obsolete</i>
	Landing Entrance Arrangement - Automatic Two Panel Side Opening (MRLi)	20-D17-2	17/06/10
	Landing Entrance Arrangement - Automatic Two Panel Centre Opening	20-D18	17/06/10
	Landing Entrance Arrangement - Automatic Two Panel Centre Opening (MRLi)	20-D18-1	17/06/10
	Electrical Requirements for MRC-SM or MRC-RM	20-D21	24/02/11
	MRC Electrical Capabilities	20-D26	17/06/10
	Electrical Requirements by Electrical Contractor for MRC	20-D27	17/06/10
	Electrical Current Loadings and Fuse Ratings for MRC	20-D28	17/06/10
	Maxilift Noise Levels	20-D29	24/02/11
	MRC Oil Cooler Option	20-D30	17/06/10
	Hydraulics Selection	20-D31	24/02/11
	Hydraulic Specifications - 8 Person MRLi (Maxilift)	20-D32	24/02/11
	Hydraulic Specifications - 10 Person MRLi (Maxilift)	20-D33	24/02/11
	Hydraulic Specifications - 13 Person MRLi (Maxilift)	20-D34	24/02/11
	Landing Entrance Cut-Out Details	20-D35	17/06/10
	Landing Entrance Cut-Out Details - MRLi	20-D37	17/06/10
	Hydraulic Specification - 16 Person (Maxilift)	20-D38	17/06/10
	Hydraulic Specification - 16 Person MRLi (Maxilift)	20-D39	24/02/11

Contents-0-1

24/02/11

Hydraulic Passenger Lift Range

Section 1

	<i>Reference</i>
Models & Door Arrangements - Maxilift	1-1
Withdrawn 17/7/97	1-2
Withdrawn 17/7/97	1-3
Withdrawn 17/7/97	1-4
Reduced Headroom range - Door Options - 6-8 Persons	1-5
Maxilift range - Door Options - 6-16 Persons	1-6
Selection Process	1-7
Maxilift Philosophy	1-8
Acceleration Curve	1-9

Waiver:

This data sheet is for guidance only and must not be used for proper working drawings. Please contact Stannah Lifts for particular details before proceeding. Owing to our policy of continual improvement we reserve the right to alter specifications and dimensions without prior notice.

MAXILIFT

Stannah

Models & Door Arrangements

Key to Model Ref. e.g. A wall mounted 8 Person Maxilift with MX finish and 2 panel side opening doors on the car and landing entrances positioned at X would be M8/MX/2S/2S/X/W

Model	Car finish				Car door		Landing door		Entrance positions available			Lift well design	
	P	M	MX	MXL	2C	2S	2C	2S	X	Y	Z	W	S
P6	P					2S		2S	X or Z or X & Z			W or S	
P8	P				2C	2S	2C	2S	X or Z or X & Z or X & Y			W or S	
M6		Any Finish				2S		2S	X or Z or X & Z			W or S	
M8					2C	2S	2C	2S	X or Z or X & Z or X & Y			W or S	
M10					2C		2C		X or Z or X & Z			W	
M13-1 Stretcher					2C	2S	2C	2S	X or Z or X & Z			W	
M13-2 Square					2C		2C			Y		W	
M16					2C		2C		Y			W	

Key to abbreviations - See above for selection/choice						
Model type	Model range (persons)	Car finish	Car door	Landing door	Entrance positions available	lift well design
Reduced Headroom (P) = 2000 car height	P6, P8 or	Reduced Headroom (P)	(2C) 2 panel centre opening	(2C) 2 panel centre opening		W = wall mounted
Maxi (M) = 2200 car height	M6, M8, M10, M13-1, M13-2, M16	Maxi: M Economy MX Premium MXL Luxury	(2S) 2 panel side opening	(2S) 2 panel side opening		S = structure supported



**Door Options
for Reduced Headroom models 6 & 8**

MAXILIFT

All models are suitable for wheelchair access in accordance with EN81-70.



Stannah

Reduced Headroom Model	Plan View & Type	Car doors	Landing doors	Cost Band £	⊕	⊖
6 Persons	 Fully Auto 2S / 2S	Ⓢ Auto 2 panel side opening	Ⓢ Auto 2 panel side opening	Medium - High	<ul style="list-style-type: none"> • Medium well width • Fully automatic 	<ul style="list-style-type: none"> • Higher cost
8 Persons	 Fully Auto 2C / 2C	Ⓢ Auto 2 panel centre opening	Ⓢ Auto 2 panel centre opening	Medium	<ul style="list-style-type: none"> • Prestigious • Fully automatic • Faster door opening 	<ul style="list-style-type: none"> • Largest well width • Available only on 8 person due to well size
	 Fully Auto 2S / 2S	Ⓢ Auto 2 panel side opening	Ⓢ Auto 2 panel side opening	Medium - High	<ul style="list-style-type: none"> • Medium well width • Fully automatic 	<ul style="list-style-type: none"> • Higher cost

Door Options
for Maxi models 6, 8, 10, 13 & 16 Persons

MAXILIFT



All models suitable for wheelchair access in accordance with EN81-70

Stannah

Maxi Model	Plan View & Type	Car doors	Landing doors	Cost Band £	⊕ Pros and Cons (The "Trade-Off") ⊖
6 Persons	Fully Auto 2S / 2S	Ⓢ Auto 2 panel side opening	Ⓢ Auto 2 panel side opening	Medium - High	<ul style="list-style-type: none"> • Medium well width • Fully automatic • Higher cost
8 Persons	Fully Auto 2C / 2C	Ⓢ Auto 2 panel centre opening	Ⓢ Auto 2 panel centre opening	Medium	<ul style="list-style-type: none"> • Prestigious • Fully automatic • Faster door opening • Largest well width • Available only on 8 person & above due to well size
	Fully Auto 2S / 2S	Ⓢ Auto 2 panel side opening	Ⓢ Auto 2 panel side opening	Medium - High	<ul style="list-style-type: none"> • Medium well width • Fully automatic • Higher cost
10 Persons	Fully Auto 2C / 2C	Ⓢ Auto 2 panel centre opening	Ⓢ Auto 2 panel centre opening	Medium	<ul style="list-style-type: none"> • Prestigious • Fully automatic • Faster door opening • Spacious car size • Large well size
13 Persons	Fully Auto 2C / 2C	Ⓢ Auto 2 panel centre opening	Ⓢ Auto 2 panel centre opening	Medium	<ul style="list-style-type: none"> • Prestigious • Fully automatic • Faster door opening • Spacious car size • Large well size
	Fully Auto 2S / 2S	Ⓢ Auto 2 panel side opening	Ⓢ Auto 2 panel side opening	Medium - High	<ul style="list-style-type: none"> • Narrower well width • Fully automatic • Suitable for stretchers • Higher cost
16 Person	Fully Auto 2C / 2C	Ⓢ Auto 2 panel centre opening	Ⓢ Auto 2 panel centre opening	Medium	<ul style="list-style-type: none"> • Prestigious • Fully automatic • Faster door opening • Spacious car size • Large well size

Selection Process

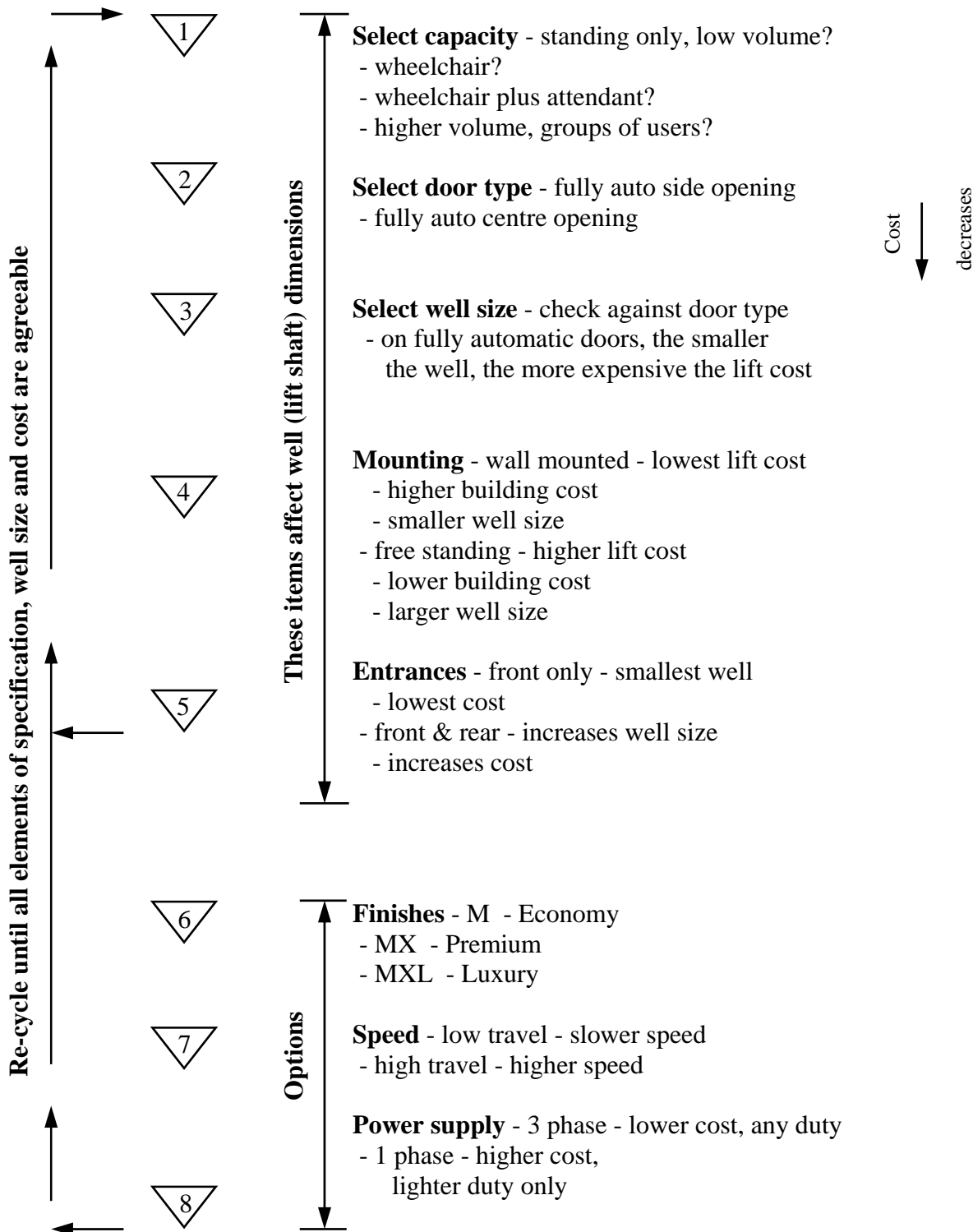

Maxilift Philosophy

1. *To rationalise production*

- Lower labour costs
- Lower material costs
- Improves margins
- Improves systems
- Increased productivity

All these help us to stay in business as they reduce our costs.

2. *Makes life easier for our customer (and us!)*

- The selection process is easier
- Less leaflets
- Less drawings
- More comprehensive data, at-a-glance
- Can see how well sizes vary with door type
- Can see how FX or WM affect well size
- Can see Part 'M' info easily
- Finishes are easier to select as well as options

3. *Tangible benefits*

- Short delivery
- 6 Person lift is the most cost effective model for wheelchair access
- 8 Person lift (the most popular size) has smaller well and can also fit old well size
- Pit reduced from 1300 to 1100 (lower building costs)
- Real compliance with EN81-2 and EN81-70
- Can see Part 'M' info easily
- Fire resistance standard

* Customer to check wheelchair size (6 person suitable for manual wheelchair in EN 12183 or electrically powered wheelchair of class A in EN 12184)

Acceleration Curve

Why is it not advisable to have a fast lift on low travel jobs?

- 1) Because higher speeds are significantly more expensive.
- 2) Because the lift takes time to accelerate and decelerate and is unlikely to reach full speed on low travel jobs.

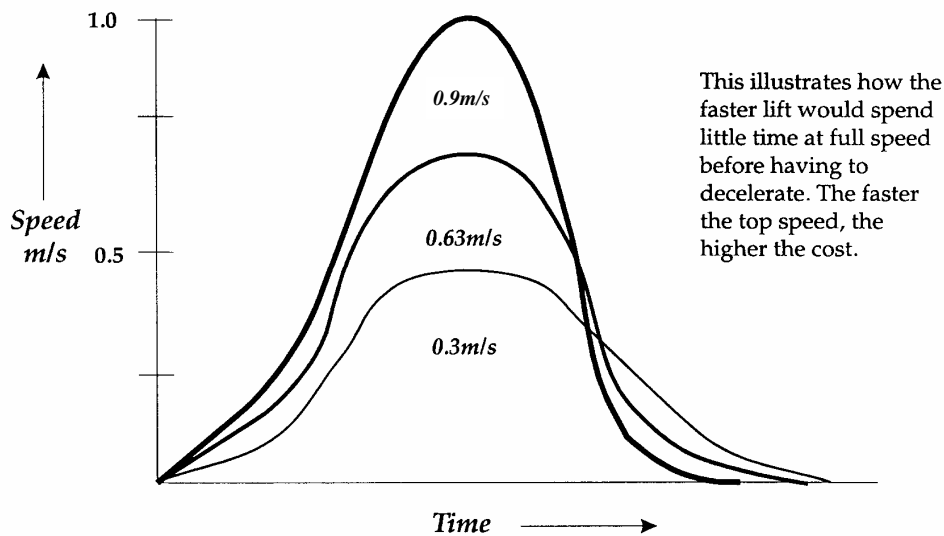

- 3) The time taken on a slower lift is only marginally longer.
- 4) The slower speed lift will use far less electricity, so saving operational costs.

Lift Speed	Acceleration Time	Acceleration Distance	Deceleration Time	Deceleration To Stopping
0.16m/s	1.0 sec	50mm	2.0 sec	275mm
0.3m/s	2.5 sec	200mm	3.5 sec	600mm
0.4m/s	2.5 sec	300mm	4.0 sec	800mm
0.5m/s	3.0 sec	400mm	4.0 sec	1000mm
0.63m/s	3.0 sec	500mm	4.0 sec	1200mm
0.9m/s	4.0 sec	750mm	5.0 sec	1800mm

Hydraulic Passenger Lift Range

Section 2

Reference

Model specifications	- General	2-1
	- Reduced Headroom range	2-2
	- Maxilift range	2-3

Waiver:

This data sheet is for guidance only and must not be used for proper working drawings. Please contact Stannah Lifts for particular details before proceeding. Owing to our policy of continual improvement we reserve the right to alter specifications and dimensions without prior notice.

MAXILIFT

Stannah

6 - 16 Person Hydraulic Passenger Lift Range to EN81 SPECIFICATION

LIFT CAR	CAR CAPACITY	:	• 6-16 Person (450 - 1200Kg)
	CAR FLOOR SIZE	:	• As individual model sheets
	CAR HEIGHT	:	• 2200mm - nominal Maxi range (clear height 2130mm) • 2000mm - Reduced Headroom range (clear height 2030mm)
	ENTRANCE TO LIFT CAR	:	• Single front only (standard) • Through car front and rear (optional)
	CAR DOOR OPTIONS	:	• Adjacent entrances (optional on 8 & 16 Person model) • 2S = Two panel automatic side opening • 2C = Two panel automatic centre opening

FINISHES	See separate finishes sheets and brochure for details		
-----------------	---	--	--

BUILDING	NUMBER OF STOPS	:	• Up to 7 floors
	TRAVEL	:	• Maximum 18m
	WELL SIZE	:	• As individual model sheets
	HEADROOM	:	• 3400mm - Maxi range (see data sheet 20-D2 & 20-D3) • 3200mm - Reduced Headroom range
	PIT	:	• 1100mm - (see 20-D1 & 20-D3)
	MOUNTING	:	• Wall mounted (standard) • Structure mounted (optional on 6P and 8P)
	CLEAR ENTRANCE MACHINE ROOM	:	• As individual model sheets

DRIVE - HYDRAULIC	DRIVE SYSTEM	:	• GMV two speed electro-hydraulic pump, submerged motor/screw type pump unit. Lift supplied complete with oil and hydraulic pipe • Max travel for 1:1 direct acting with standard pit depth & headroom: - up to 2.7m on Reduced Headroom range - up to 2.9m on Maxilift range Up to 3.5m travel can be achieved with increased pit and/or headroom (see data sheet 20-D3)
------------------------------	--------------	---	---

SPEED	SPEED OPTIONS	:	• 0.15, 0.3, 0.4, 0.5, 0.63, 0.86m/s
	SUPPLY VOLTAGE	:	• 415V, 50Hz, 3 phase (standard) • 240V, single phase at speed of 0.15m/s (optional)

LANDING DOORS	DOOR OPTIONS	:	• 2S = Two panel automatic side opening • 2C = Two panel automatic centre opening
	FIRE RATING	:	• 120 mins fire rated standard on 2 panel automatic doors

CONTROLS	LANDING PUSH BUTTON STATION	:	• Mounted within landing surround uprights
	CONTROLS	:	• Automatic push button or Single button collective (standard) • 2 button fully directional collective (optional) • Highest call down collective (optional) • Duplex interconnected (optional)
	CAR CONSOLE	:	• Full height vertical console
	CONSOLE POSITION CONSOLE CONTROLS	:	• Pushes between 900 and 1200mm above car floor • Door open push button & car preference goods control (standard)

Note 1: All wiring, trunking, tubing & control gear to operate the lift is supplied as standard.

Note 2: Many other control options are available, please ask for more details.

Waiver:

This data sheet is for guidance only and must not be used for proper working drawings. Please contact Stannah Lifts for particular details before proceeding. Owing to our policy of continual improvement we reserve the right to alter specifications and dimensions without prior notice.





MAXILIFT

Stannah

Reduced Headroom SPECIFICATION

One model only

Persons : 6, 8

Reduced Height Car = 2000					
Reduced Headroom Range - P6, P8					S = Standard O = Optional
Ceiling		Powder coated Flush Ceiling			S
Walls		Vinyl skin plate			S
Push button console		Full height, Vertical Console			S
Floor		By others (5mm max height) Tiles			S O
Lift door selection	Ref.	Plan View	Car doors	Landing doors	
	2S / 2S		2S Auto 2 panel side opening	2S Auto 2 panel side opening	P6 & P8
	2C / 2C		2C Auto 2 panel centre opening	2C Auto 2 panel centre opening	P8
Skirting		No skirting			S
Mirror			Single Entry - Half height at B	S	
			Thro & Adj - Half Height at A	S	
			No mirror	O	
Handrail			Handrail at A or B (Std. on Thro' cars)	S	
			Handrails at A & B (Not Thro' car)	O	
			Handrails at A, B & C (Not Thro' car)	O	
			Handrails at A & C (Thro' car)	O	
Mounting		Wall mounted ^① Supporting structure ^②			S O
Drive (hydraulic)		Direct acting (1:1) Indirect acting (2:1)			O O
Speeds (m/s)		0.15 (Single Phase Only) 0.3) 0.4) 0.5) 3 Phase 0.63) 0.86)			O S O O O O
Control system		Automatic push button or Single button collective			S
Supply voltage		415V, 50Hz, 3 phase 240V, 50Hz, 1 phase (Available on speeds of 0.15m/s only)			S O

See separate Finishes Sheets and Maxilift Brochure for illustrations

① Direct acting (1:1) available up to 2.7m travel with standard pit depth and headroom. Up to 3.5m travel can be achieved with increased pit and / or headroom see 20-D3 in section 20.

② Indirect acting (2:1) available up to 18m travel.





Waiver:

This data sheet is for guidance only and must not be used for proper working drawings. Please contact Stannah Lifts for particular details before proceeding. Owing to our policy of continual improvement we reserve the right to alter specifications and dimensions without prior notice.

MAXILIFT

Stannah

Maxi SPECIFICATION M, MX & MXL models Persons : 6, 8, 10, 13 & 16

Full Height Car = 2200					S = Standard O = Optional		
Maxi Range - M6, M8, M10, M13 & M16					M	MX	MXL
Ceiling		M - White downlighter effect suspended ceiling MX 1 - Coloured 6 spot downlighter effect suspended ceiling MX 2 - Coloured multi-spot downlighter effect suspended ceiling MXL 1 - Coloured 9 spot downlighter effect suspended ceiling MXL 2 - 6 spot downlighter suspended ceiling			S O O O O	O S S O O	O O S S S
Walls		Vinyl skin plate Walls carpeted by others Laminates on walls Stainless Steel			S - - O	S - - O	O O S O
Push button console		Full height, Vertical Console in vinyl skin plate Full height, Vertical Console in stainless steel			S O	S O	O S
Floor		By others (5mm max height) Wood or Slate effect flooring Tiles			S O O	S O O	S O O
Lift door selection	Ref.	Plan View	Car doors	Landing doors			
	2S / 2S		2S Auto 2 panel side opening	2S Auto 2 panel side opening	M6, M8 M13-1	M6, M8 M13-1	M6, M8 M13-1
	2C / 2C		2C Auto 2 panel centre opening	2C Auto 2 panel centre opening	M8, M10, M13-1, M13-2 M16	M8, M10, M13-1, M13-2 M16	M8, M10, M13-1, M13-2 M16
Skirting		Skirting in vinyl skin plate Skirting in stainless steel			- -	S O	O S
Mirror			Half height B (not thro' car or adj) Half height A (Std. on thro car & adj) Half height A & B Half height A & B & C		S S - -	S S O O	S S O O
			Full height A Full height B (not thro' car or adj) Full height A & B, A & B & C, or B & C		O O -	O O O	O O O
			No mirror		O	O	O
			Handrail at A or B (A is Std. on Thro' cars) Handrails at A & B (not thro' car)		S O	S O	S O
Handrail			Handrails at A, B & C (not thro' car or adj) Handrails at A & C (on thro' car)		O O	O O	O O
Mounting			Wall mounted Supporting structure ^① (not available on M10, M13 & M16)			S O	S O
Drive (hydraulic)		Direct acting (1:1) ^② Indirect acting (2:1)			O O	O O	O O
Speeds (m/s)		0.15 (Single Phase Only) 0.3) 0.4) 3 Phase 0.5) 0.63) 0.86)			O S O O - -	O S O O O O	O S O O O O
Control system		Automatic push button or Single button collective Highest call down collective Two button fully directional collective Duplex interconnected			S - - -	S O O O	S O O O
Supply voltage		415V, 50Hz, 3 phase 240V, 50Hz, 1 phase (Available on speeds of 0.15m/s only)			S O	S O	S O

See separate Finishes Sheets and Maxilift Brochure for illustrations

- ① Direct acting (1:1) available up to 2.9m travel with standard pit depth and headroom. Up to 3.5m travel can be achieved with increased pit and / or headroom see 20-D3 in section 20.
- ② Indirect acting (2:1) available up to 18m travel.

MAXILIFT

Hydraulic Passenger Lift Range

Stannah

Section 6

Reference

Withdrawn 17/10/06	6-1
Withdrawn 17/10/06	6-3
Withdrawn 17/10/06	6-5
Withdrawn 17/10/06	6-6
6 Person - Architects details	6-7
6 Person - Architects details - MRC	6-8

Waiver:
 This data sheet is for guidance only and must not be used for proper working drawings. Please contact Stannah Lifts for particular details before proceeding. Owing to our policy of continual improvement we reserve the right to alter specifications and dimensions without prior notice.

MAXILIFT

Stannah

6 Person (450kg)

Wall Mounted Models - Lifting beam supplied by builder
 Structure Mounted Models - Lifting beam supplied with lift

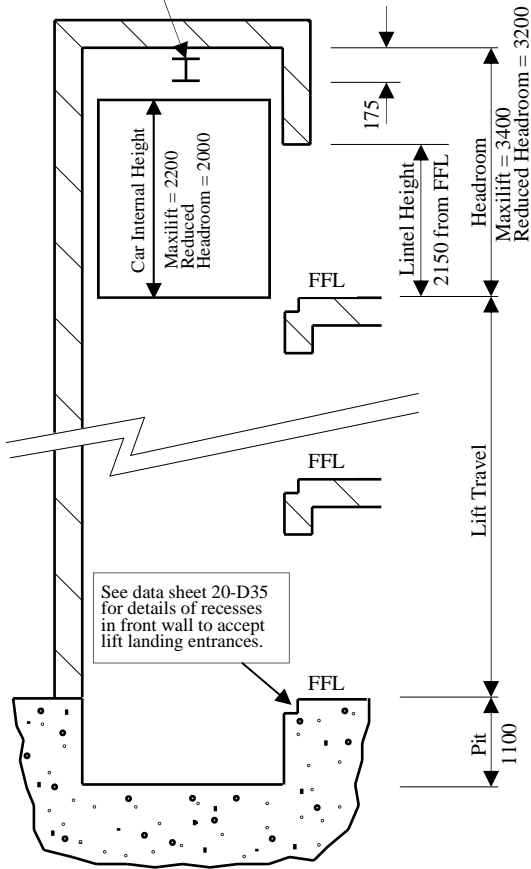

See data sheet 20-D35 for details of recesses in front wall to accept lift landing entrances.

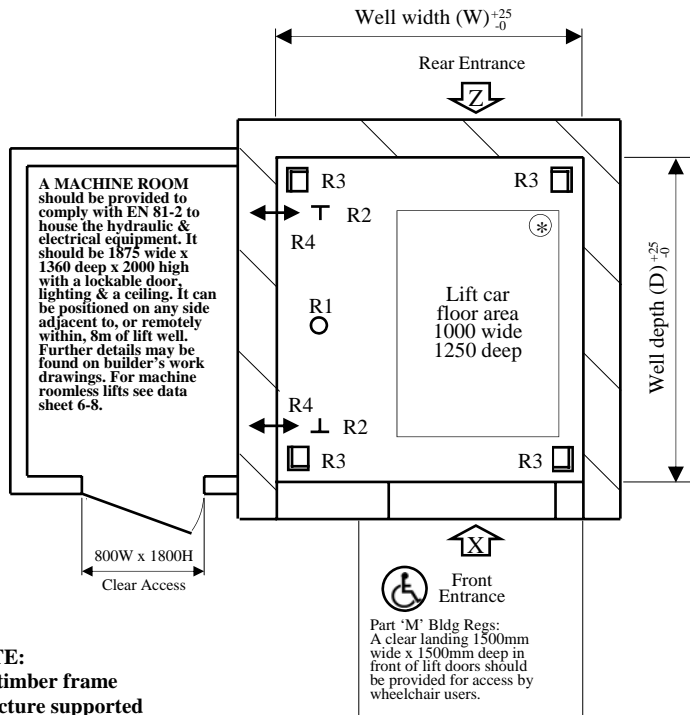

A MACHINE ROOM should be provided to comply with EN 81-2 to house the hydraulic & electrical equipment. It should be 1875 wide x 1360 deep x 2000 high with a lockable door, lighting & a ceiling. It can be positioned on any side adjacent to, or remotely within, 8m of lift well. Further details may be found on builder's work drawings. For machine roomless lifts see data sheet 6-8.

NOTE:
 For timber frame Structure supported Lifts please increase the shaft widths and depths by 50mm.

Part 'M' Bldg Regs: A clear landing 1500mm wide x 1500mm deep in front of lift doors should be provided for access by wheelchair users.

EQUIVALENT DEAD LOADS IMPOSED DUE TO LIFT OPERATION (kg)

		Wall Mounted Models	Structure Mounted Models	Type of Loading
Lift Pit/Floor	R1	2710	2710	Load due to car weight + load + hydraulic cylinder
	R2	2490	2490	Load due to car buffering or safety gear operation
	R3	not applicable	797	Load at base of structure in each corner
Side Wall	R4	197	100†	Push in/Pull out load

†Applies to lift structure on all sides in the pit, headroom, at each floor level, and at a maximum of 4m intervals.

IMPORTANT

On Wall Mounted Models, Unistrut inserts ref P3270 to be built into lift pit and lift well walls by builder *before* installation. See specific Builder's Work Drawings for precise details.

MODEL REF	LIFT DOORS ARRANGEMENT	WALL MOUNTED MODELS				STRUCTURE MOUNTED MODELS				Lift Car Clear Entrance	
		PLAN WELL DIMENSIONS				PLAN WELL DIMENSIONS					
		Front Entrance X or Z		Front & Rear Entrance X & Z		Front Entrance X or Z		Front & Rear Entrance X & Z		W	H
P6-2S 2S M6-2S 2S (800)	Auto 2 panel side opening 2S	W	D	W	D	W	D	W	D	800	2000
	Car & Landing Door Type										

Note: Shaft sizes are for guidance purposes only and subject to change. It is crucial that you contact Stannah concerning your specific requirements.

Part 'M': This model complies with the dimensions of Part 'M' of the Building Regulations for lifts installed in a dwelling. Buildings other than a dwelling require a lift with a capacity of 8 persons or more.

EN81-70: This model is also designed to take a manual or class A electrically powered wheelchair in accordance with BS EN81-70: *Accessibility to lifts for persons including persons with disability.*

6-7
15/11/11

Waiver:

This data sheet is for guidance only and must not be used for proper working drawings. Please contact Stannah Lifts for particular details before proceeding. Owing to our policy of continual improvement we reserve the right to alter specifications and dimensions without prior notice.

MAXILIFT

Stannah

Machine Room-Less

Machine Room Cabinet

MRC

6 Person (450kg)

Travel: 15.4m max.
Speed: 0.63m/s max.

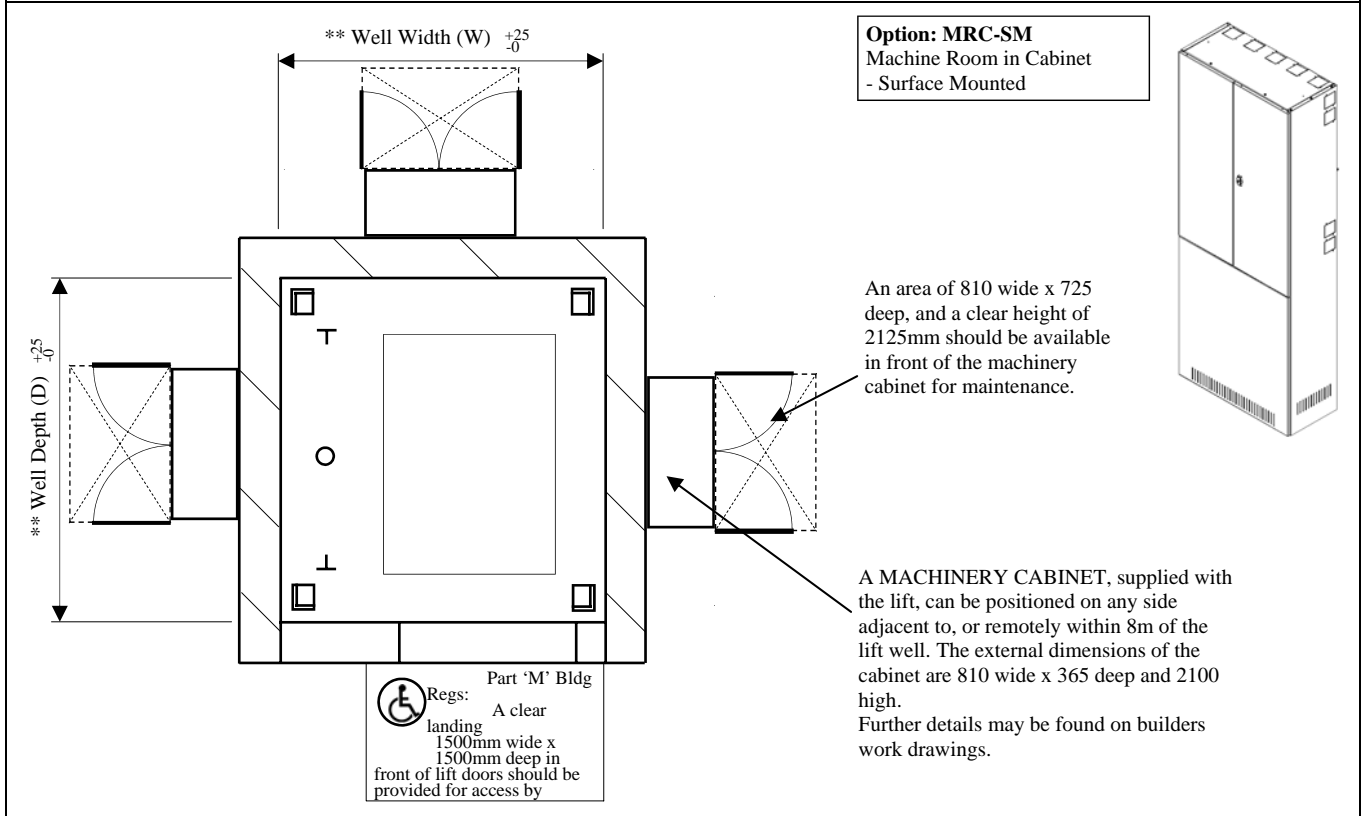
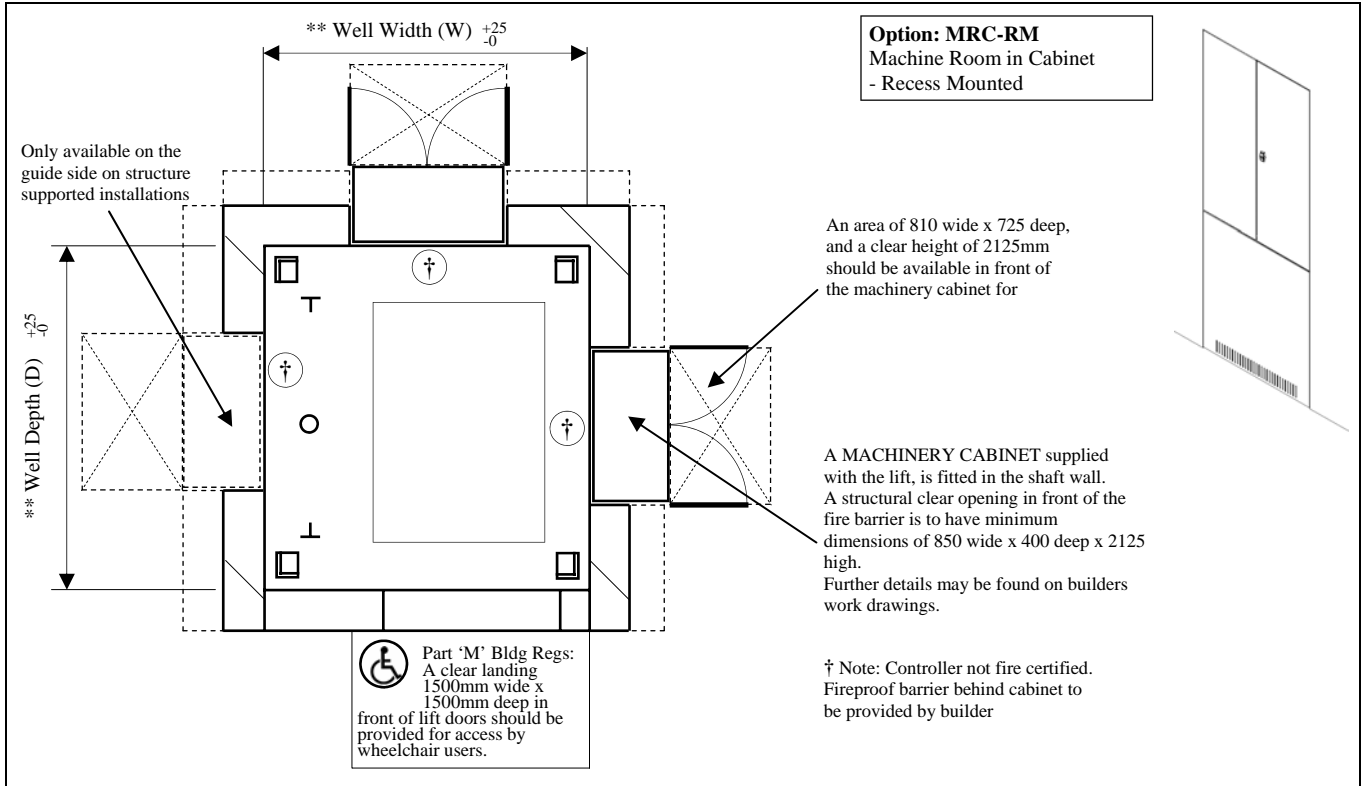

** See datasheet 6-7 for information on well dimensions, imposed loads and general details of 6 person lifts.

MAXILIFT

Hydraulic Passenger Lift Range

Stannah

Section 8

	<i>Reference</i>
Withdrawn 17/10/06	8-1
Withdrawn 17/10/06	8-3
Withdrawn 17/10/06	8-5
Withdrawn 17/10/06	8-7
Withdrawn 17/10/06	8-8
Withdrawn 17/10/06	8-9
8 Person - Architects details - MRLi	8-12-1
8 Person - Architects details - MRLi - Alternative Controller Locations	8-12-2
8 Person - Architects details	8-13
8 Person - Architects details - MRC	8-14

Waiver:
 This data sheet is for guidance only and must not be used for proper working drawings. Please contact Stannah Lifts for particular details before proceeding. Owing to our policy of continual improvement we reserve the right to alter specifications and dimensions without prior notice.

MAXILIFT

Stannah

Machine Room-Less

Option: MRLi-EC
 Machine Room-less
 - Entrance Controller

Totally Machine Room Free (MRLi)

MRLi

8 Person (630kg)

Wall Mounted Models - Lifting beam supplied by builder
 Structure Mounted Models - Lifting beam supplied with lift.

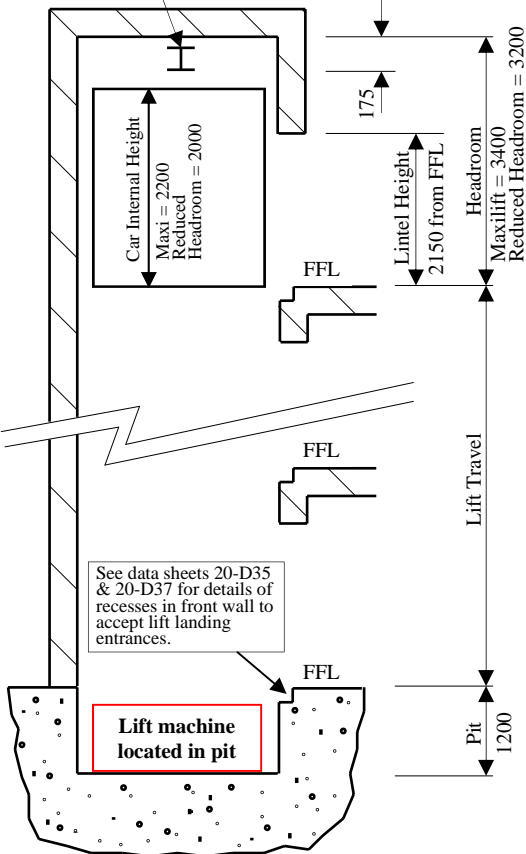

NOTE:
 For timber frame Structure supported Lifts please increase the shaft widths and depths by 50mm.

A 1hr certified lift controller forms part of the lift entrance and can be positioned at any landing (the lowest landing is preferred). See data sheet 20-D37 for cut out details. Further details may be found on builders work drawings.

For alternative controller locations see data sheet 8-12-2

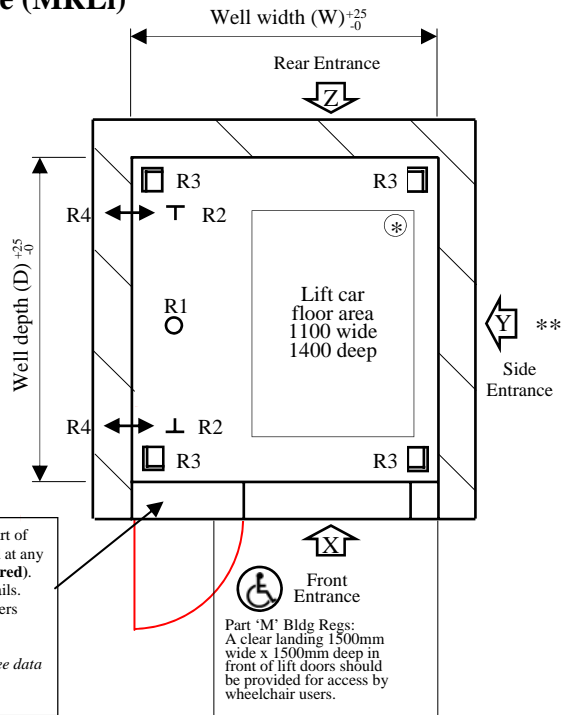

See data sheets 20-D35 & 20-D37 for details of recesses in front wall to accept lift landing entrances.

Lift machine located in pit

EQUIVALENT DEAD LOADS IMPOSED DUE TO LIFT OPERATION (kg)

		Wall Mounted Models	Structure Mounted Models	Type of Loading
Lift Pit Floor	R1	3325	3325	Load due to car weight + load + hydraulic cylinder
	R2	3070	3070	Load due to car buffering or safety gear operation
	R3	not applicable	885	Load at base of structure in each corner
Side Wall	R4	318	100†	Push in/Pull out load

†Applies to lift structure on all sides in the pit, headroom, at each floor level, and at a maximum of 4m intervals.

IMPORTANT

On Wall Mounted Models, Unistrut inserts ref P3270 to be built into lift pit and lift well walls by builder before installation. See specific Builder's Work Drawings for precise details.

Travel: 17.1m max.
 Speed: Up to 0.63 m/s

MODEL REF	LIFT DOORS ARRANGEMENT	Car & Landing Door Type	WALL MOUNTED MODELS						STRUCTURE MOUNTED MODELS						Lift Car Clear Entrance	
			PLAN WELL DIMENSIONS						PLAN WELL DIMENSIONS							
			Front Entrance X or Z		Front & Rear Entrance X & Z		Front & Side Entrance X & Y or Z & Y		Front Entrance X or Z		Front & Rear Entrance X & Z		Front & Side Entrance X & Y or Z & Y			
W	D	W	D	W	D	W	D	W	D	W	D	W	H			
P8-2S 2S M8-2S 2S (800)		Auto 2 panel side opening 2S	1550	1835	1550	2010	1680	2000	1700	1875	1700	2000	1750	2030	800	2000
P8-2S 2S M8-2S 2S (900)		Auto 2 panel side opening 2S	1675	1835	1675	2010	1795	2025	1825	1875	1825	2000	1890	2030	900	2000
M8-2C 2C P8-2C 2C (800)		Auto 2 panel centre opening 2C	1800	1750	1800	1880	N/A	N/A	1960	1820	1960	1880	N/A	N/A	800	2000
M8-2C 2C P8-2C 2C (900)		Auto 2 panel centre opening 2C	2000	1750	2000	1880	N/A	N/A	2160	1820	2160	1880	N/A	N/A	900	2000

Note: Shaft sizes are for guidance purposes only and subject to change. It is crucial that you contact Stannah concerning your specific requirements.

Part 'M': This lift car size is recommended in Part 'M' of the building Regs and will carry a wheelchair and attendant.

** While lifts with an adjacent (Y) entrance do not comply with the dimensions of Part 'M' of the building regulations, it has been specially designed to take a wheelchair and attendant.

Machine Room-Less
 MRLi
8-12-1
 24/02/11

Waiver:

This data sheet is for guidance only and must not be used for proper working drawings. Please contact Stannah Lifts for particular details before proceeding. Owing to our policy of continual improvement we reserve the right to alter specifications and dimensions without prior notice.

MAXILIFT

Stannah

Machine Room-Less

Alternative Controller Locations (when not desired in the landing entrance as in 8-12-1)

MRLi

8 Person (630kg)

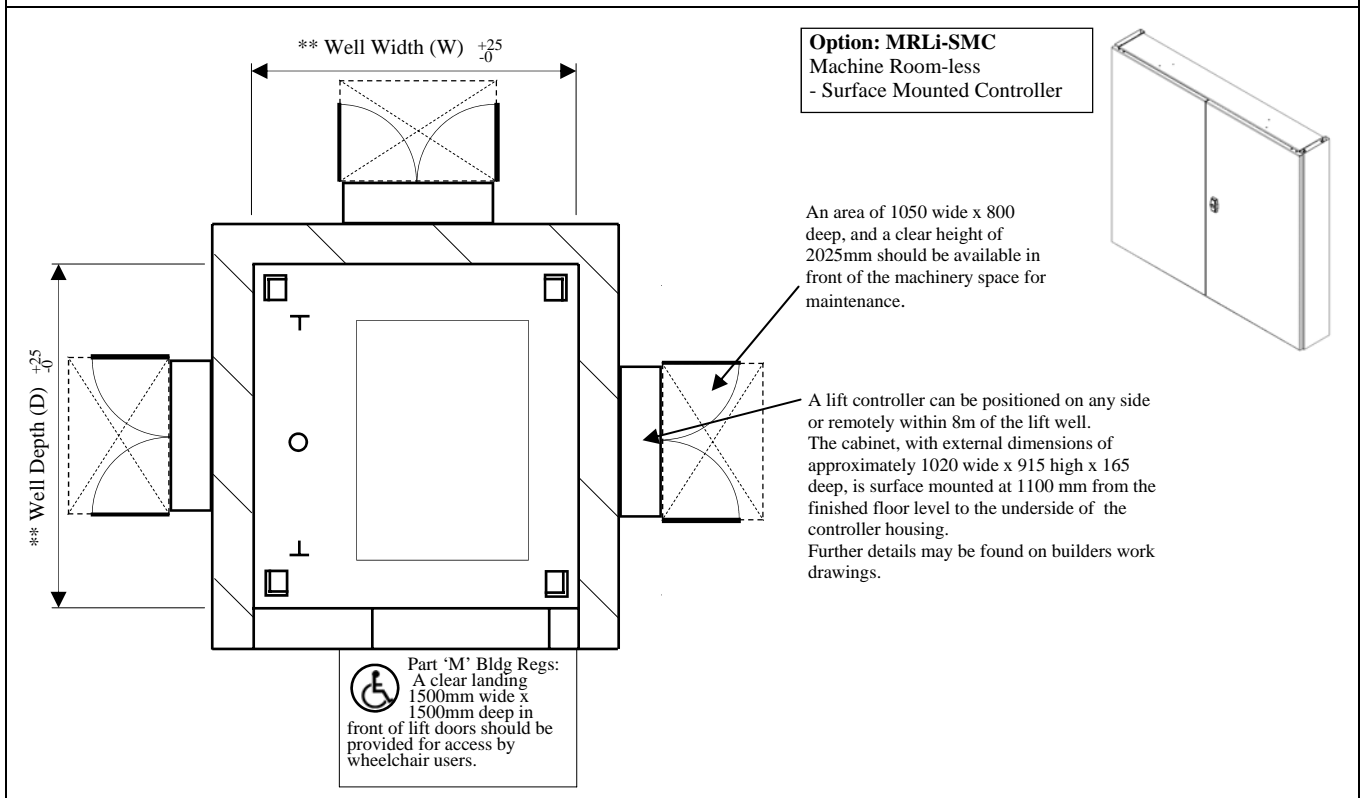
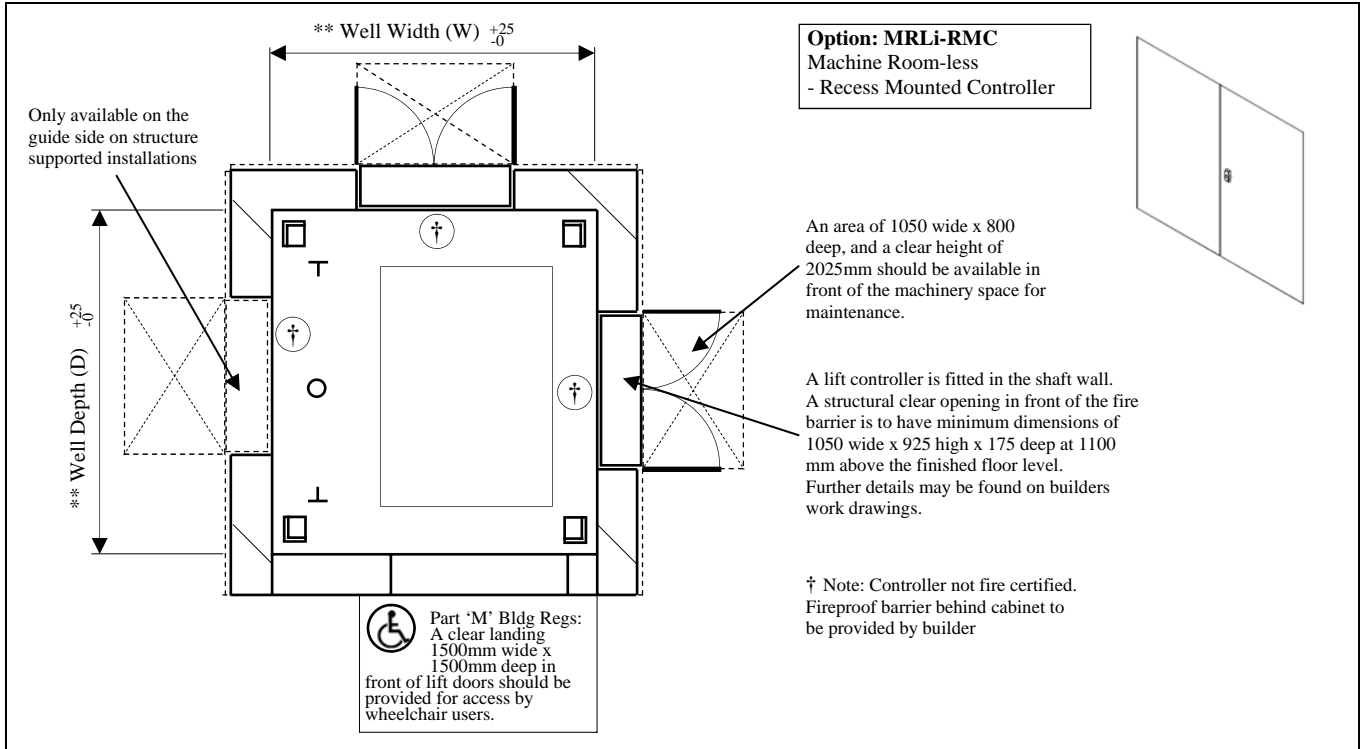

** See datasheet 8-12-1 for information on well dimensions, imposed loads and details of 8 person MRLi lifts.

Waiver:

This data sheet is for guidance only and must not be used for proper working drawings. Please contact Stannah Lifts for particular details before proceeding. Owing to our policy of continual improvement we reserve the right to alter specifications and dimensions without prior notice.

MAXILIFT

Stannah

8 Person (630kg)

Wall Mounted Models - Lifting beam supplied by builder
Structure Mounted Models - Lifting beam supplied with lift.

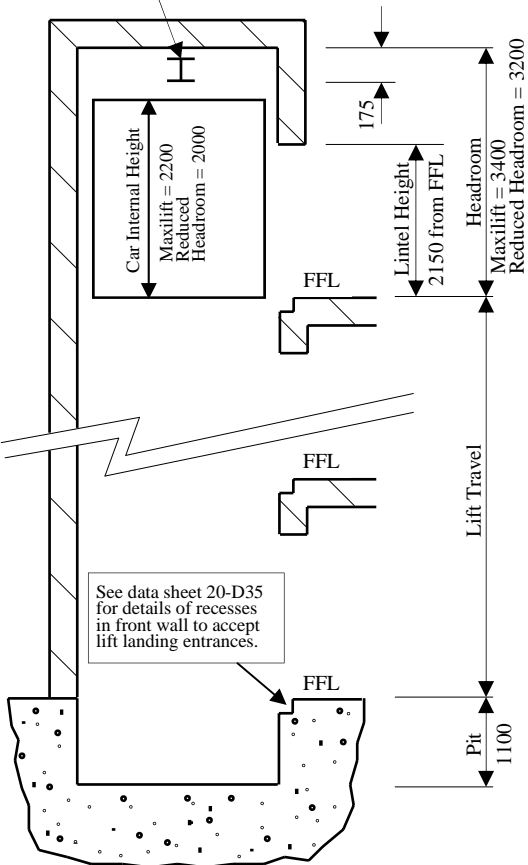

See data sheet 20-D35 for details of recesses in front wall to accept lift landing entrances.

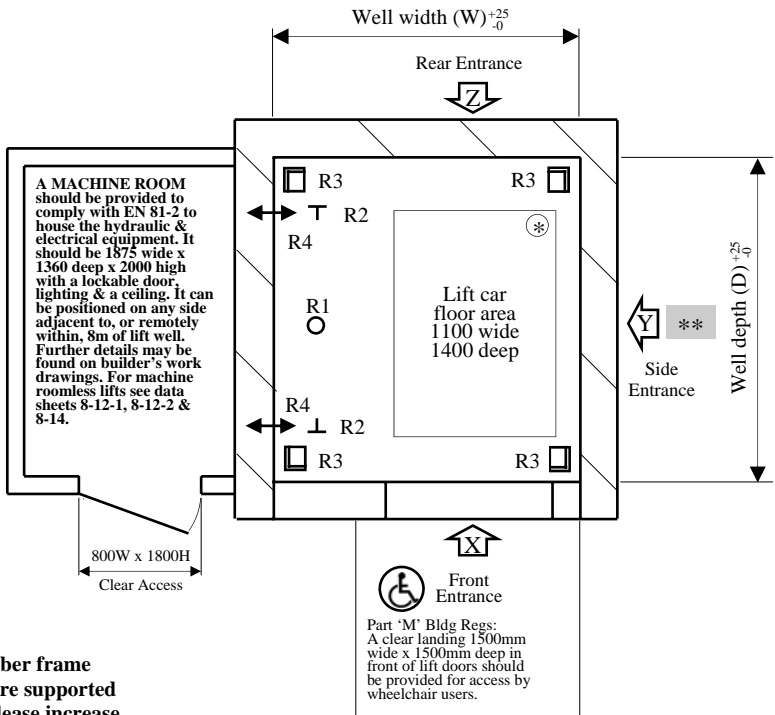

A MACHINE ROOM should be provided to comply with EN 81-2 to house the hydraulic & electrical equipment. It should be 1875 wide x 1360 deep x 2000 high with a lockable door, lighting & a ceiling. It can be positioned on any side adjacent to, or remotely within, 8m of lift well. Further details may be found on builder's work drawings. For machine roomless lifts see data sheets 8-12-1, 8-12-2 & 8-14.

NOTE:
For timber frame Structure supported Lifts please increase the shaft widths and depths by 50mm.

Part 'M' Bldg Regs: A clear landing 1500mm wide x 1500mm deep in front of lift doors should be provided for access by wheelchair users.

EQUIVALENT DEAD LOADS IMPOSED DUE TO LIFT OPERATION (kg)

		Wall Mounted Models	Structure Mounted Models	Type of Loading
Lift Pit Floor	R1	3325	3325	Load due to car weight + load + hydraulic cylinder
	R2	3070	3070	Load due to car buffering or safety gear operation
	R3	not applicable	885	Load at base of structure in each corner
Side Wall	R4	318	100†	Push in/Pull out load

†Applies to lift structure on all sides in the pit, headroom, at each floor level, and at a maximum of 4m intervals.

IMPORTANT

On Wall Mounted Models, Unistrut inserts ref P3270 to be built into lift pit and lift well walls by builder before installation. See specific Builder's Work Drawings for precise details.

MODEL REF	LIFT DOORS ARRANGEMENT	Car & Landing Door Type	WALL MOUNTED MODELS						STRUCTURE MOUNTED MODELS						Lift Car Clear Entrance	
			PLAN WELL DIMENSIONS						PLAN WELL DIMENSIONS							
			Front Entrance X or Z		Front & Rear Entrance X & Z		Front & Side Entrance X & Y or Z & Y		Front Entrance X or Z		Front & Rear Entrance X & Z		Front & Side Entrance X & Y or Z & Y		W	H
P8-2S 2S M8-2S 2S (800)		Auto 2 panel side opening 2S	1500	1835	1500	2010	1680	1830	1650	1875	1650	2000	1750	1910	800	2000
P8-2S 2S M8-2S 2S (900)		Auto 2 panel side opening 2S	1625	1835	1625	2010	1795	1830	1775	1875	1775	2000	1890	1950	900	2000
M8-2C 2C P8-2C 2C (800)		Auto 2 panel centre opening 2C	1800	1750	1800	1880	N/A	N/A	1960	1820	1960	1880	N/A	N/A	800	2000
M8-2C 2C P8-2C 2C (900)		Auto 2 panel centre opening 2C	2000	1750	2000	1880	N/A	N/A	2180	1820	2180	1880	N/A	N/A	900	2000

Note: Shaft sizes are for guidance purposes only and subject to change. It is crucial that you contact Stannah concerning your specific requirements.

Part 'M': This lift car size is recommended in Part 'M' of the building Regs and will carry a wheelchair and attendant.

** While lifts with an adjacent (Y) entrance do not comply with the dimensions of Part 'M' of the building regulations, it has been specially designed to take a wheelchair and attendant.

8-13
24/02/11

Waiver:

This data sheet is for guidance only and must not be used for proper working drawings. Please contact Stannah Lifts for particular details before proceeding. Owing to our policy of continual improvement we reserve the right to alter specifications and dimensions without prior notice.

MAXILIFT

Stannah

Machine Room-Less

Machine Room Cabinet

MRC

8 Person (630kg)

Travel: 15.4m max.
Speed: 0.63m/s max.

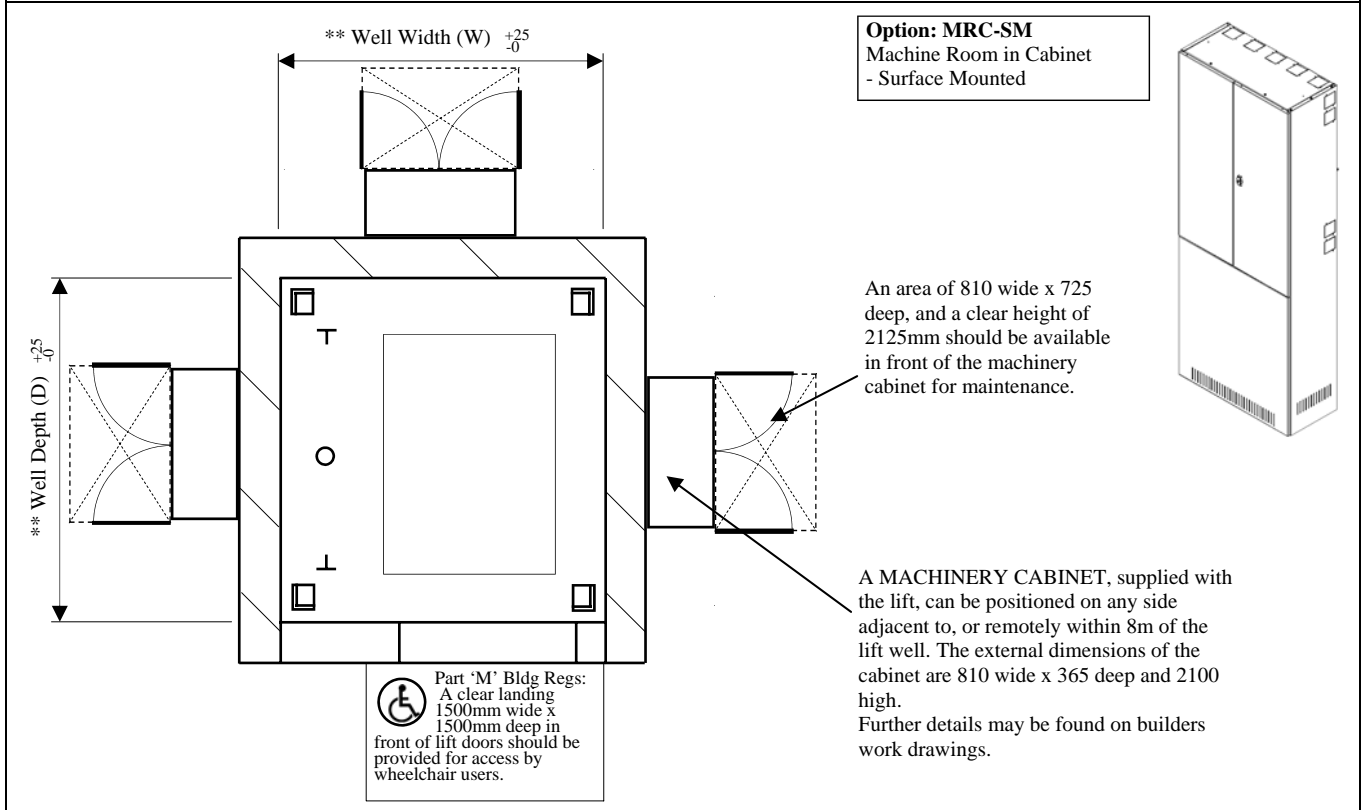
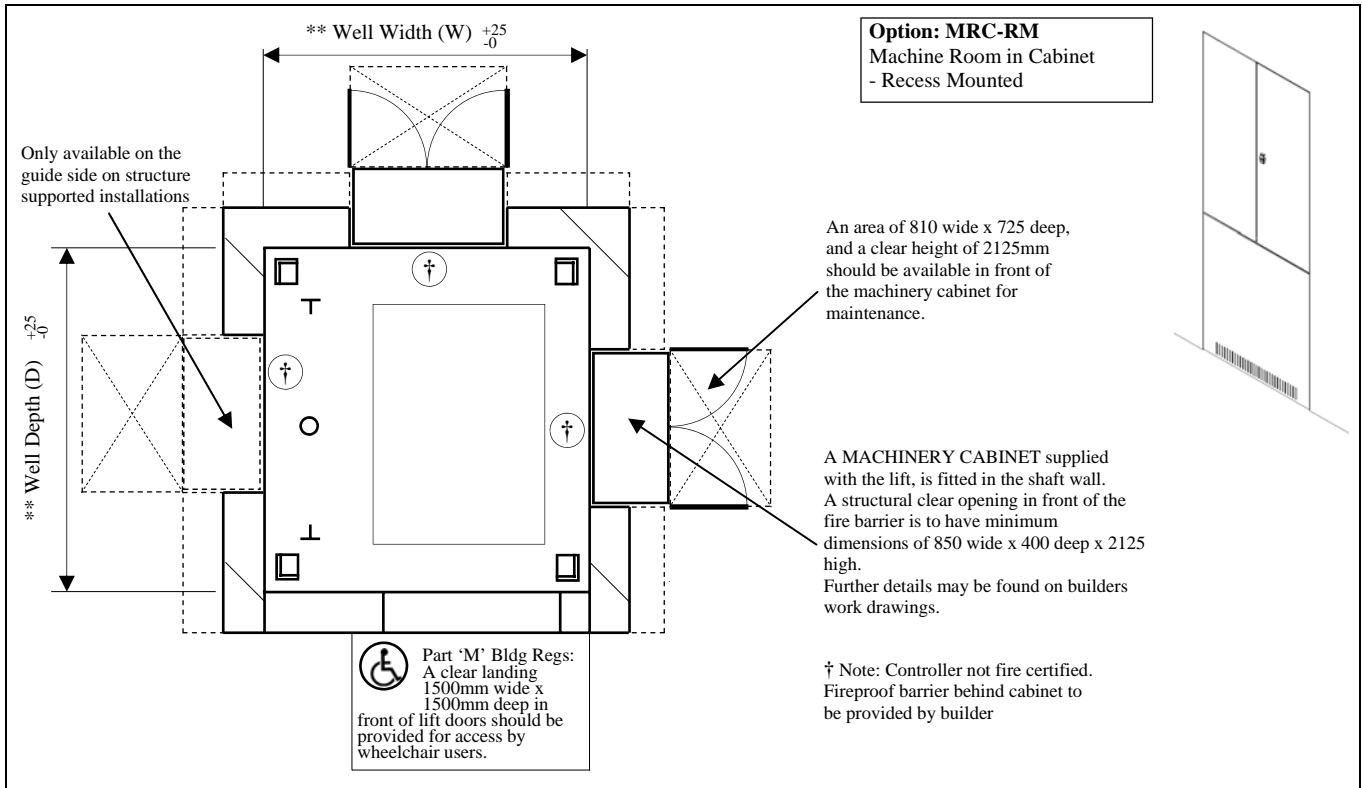

** See datasheet 8-13 for information on well dimensions, imposed loads and general details of 8 person lifts.

MAXILIFT

Hydraulic Passenger Lift Range

Stannah

Section 10

	<i>Reference</i>
10 Person - Architects details	10-1
Withdrawn 17/10/06	10-3
Withdrawn 17/10/06	10-4
10 Person - Architects details - MRLi	10-6-1
10 Person - Architects details - MRLi - Alternative Controller Locations	10-6-2
10 Person - Architects details - MRC	10-7

Waiver:

This data sheet is for guidance only and must not be used for proper working drawings. Please contact Stannah Lifts for particular details before proceeding. Owing to our policy of continual improvement we reserve the right to alter specifications and dimensions without prior notice.

MAXILIFT

Stannah

10 Person (800kg)

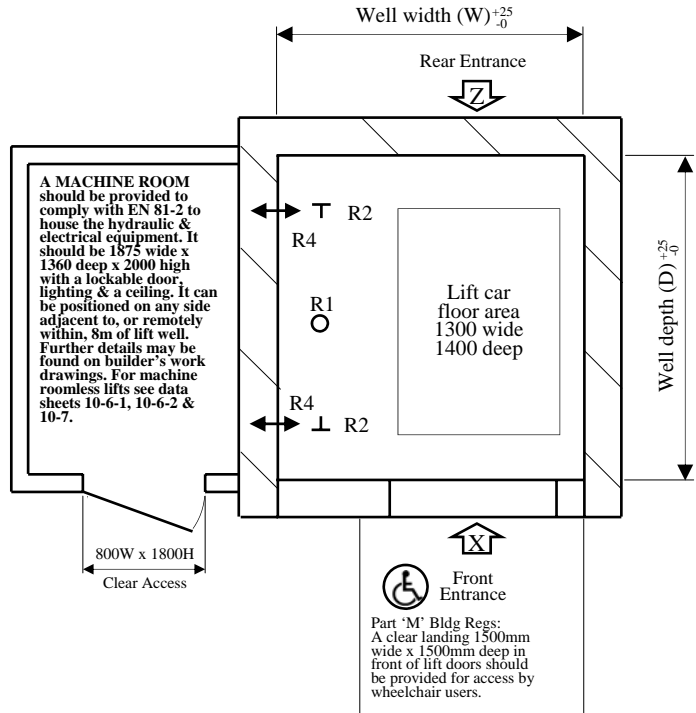
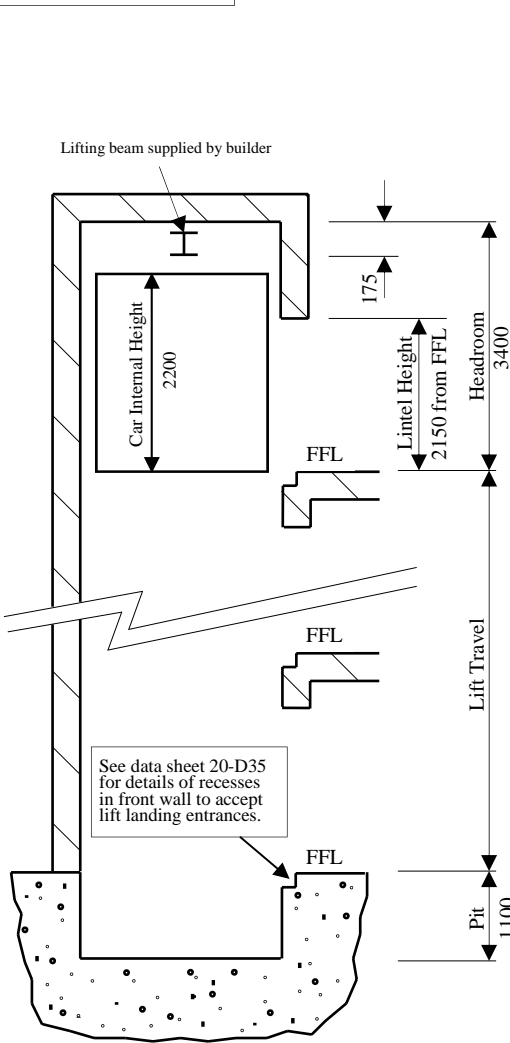

A MACHINE ROOM should be provided to comply with EN 81-2 to house the hydraulic & electrical equipment. It should be 1875 wide x 1360 deep x 2000 high with a lockable door, lighting & a ceiling. It can be positioned on any side adjacent to, or remotely within, 8m of lift well. Further details may be found on builder's work drawings. For machine roomless lifts see data sheets 10-6-1, 10-6-2 & 10-7.

EQUIVALENT DEAD LOADS IMPOSED DUE TO LIFT OPERATION (kg)

	Wall Mounted Models	Type of Loading	
		Side Wall	Lift Pit/Floor
R1	3675	Load due to car weight + load + hydraulic cylinder	
R2	3482	Load due to car buffering or safety gear operation	
R4	409	Push in/Pull out load	

IMPORTANT

On Wall Mounted Models, Unistrut inserts ref P3270 to be built into lift pit and lift well walls by builder *before* installation. See specific Builder's Work Drawings for precise details.

WALL MOUNTED MODELS

MODEL REF	LIFT DOORS ARRANGEMENT	Plan Well Dimensions				Lift Car Clear Entrance	
		Front entrance X or Z		Front & rear entrance X & Z		W	H
M10-2C 2C (800)	Auto 2 panel centre opening 2C	1900	1750	1900	1880	800	2000
M10-2C 2C (900)	Auto 2 panel centre opening 2C	2000	1750	2000	1880	900	2000

Note: Shaft sizes are for guidance purposes only and subject to change so it is crucial that you contact the supplier concerning your specific requirements.

Note: FX model (Structure Mounted) *not* available in this capacity. Wall Mounted only.

Waiver:

This data sheet is for guidance only and must not be used for proper working drawings. Please contact Stannah Lifts for particular details before proceeding. Owing to our policy of continual improvement we reserve the right to alter specifications and dimensions without prior notice.

MAXILIFT

Stannah

Machine Room-Less

Totally Machine Room Free

MRLi

10

Option: MRLi-EC
Machine Room-less
- Entrance Controller

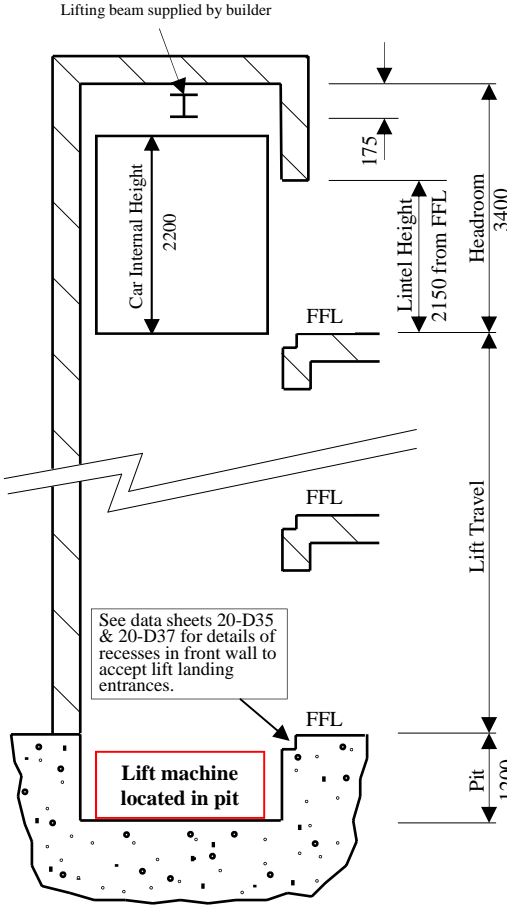

A 1 hr certified lift controller forms part of the lift entrance and can be positioned at any landing (the lowest landing is preferred). See data sheet 20-D37 for cut out details. Further details may be found on builders work drawings.
For alternative controller locations see data sheet 10-6-2

Travel: 14.8m max.
Speed: Up to 0.63 m/s

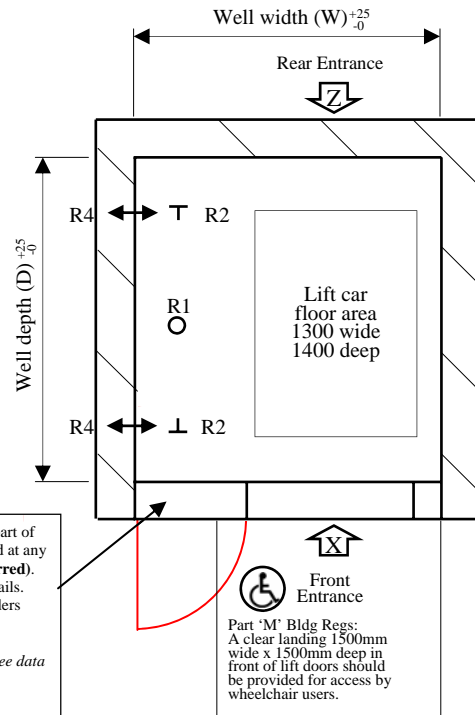

Part 'M' Bldg Regs:
A clear landing 1500mm wide x 1500mm deep in front of lift doors should be provided for access by wheelchair users.

EQUIVALENT DEAD LOADS IMPOSED DUE TO LIFT OPERATION (kg)

		Wall Mounted Models	Type of Loading
		Side Wall	R1
Lift Pit/Floor	R2	3482	Load due to car buffering or safety gear operation
	R4	409	Push in/Pull out load

IMPORTANT

On Wall Mounted Models, Unistrut inserts ref P3270 to be built into lift pit and lift well walls by builder *before* installation. See specific Builder's Work Drawings for precise details.

WALL MOUNTED MODELS

MODEL REF	LIFT DOORS ARRANGEMENT	Plan Well Dimensions				Lift Car Clear Entrance			
		Front entrance X or Z		Front & rear entrance X & Z		W	H		
		Car Doors	Landing Doors	W	D	W	D	W	H
M10-2C 2C (800)		Auto 2 panel centre opening 2C	Auto 2 panel centre opening 2C	1900	1750	1900	1880	800	2000
M10-2C 2C (900)		Auto 2 panel centre opening 2C	Auto 2 panel centre opening 2C	2000	1750	2000	1880	900	2000

Note: Shaft sizes are for guidance purposes only and subject to change so it is crucial that you contact Stannah concerning your specific requirements

Note: FX model (Structure Mounted) *not* available in this capacity. Wall Mounted only.

Machine Room-Less
MRLi
10-6-1
17/06/10

Waiver:

This data sheet is for guidance only and must not be used for proper working drawings. Please contact Stannah Lifts for particular details before proceeding. Owing to our policy of continual improvement we reserve the right to alter specifications and dimensions without prior notice.

MAXILIFT

Stannah

Machine Room-Less

Alternative Controller Locations (when not desired in the landing entrance as in 10-6-1)

MRLi

10 Person (800kg)

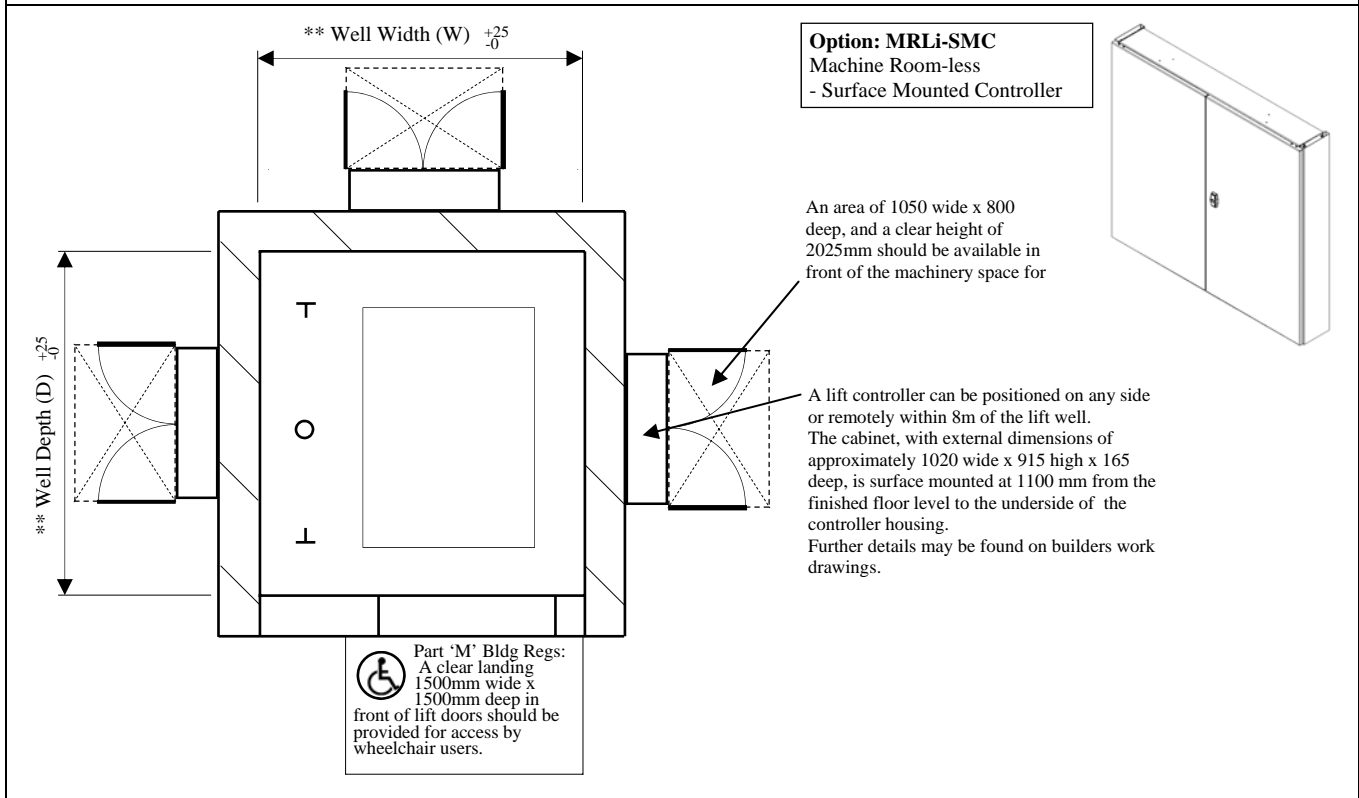
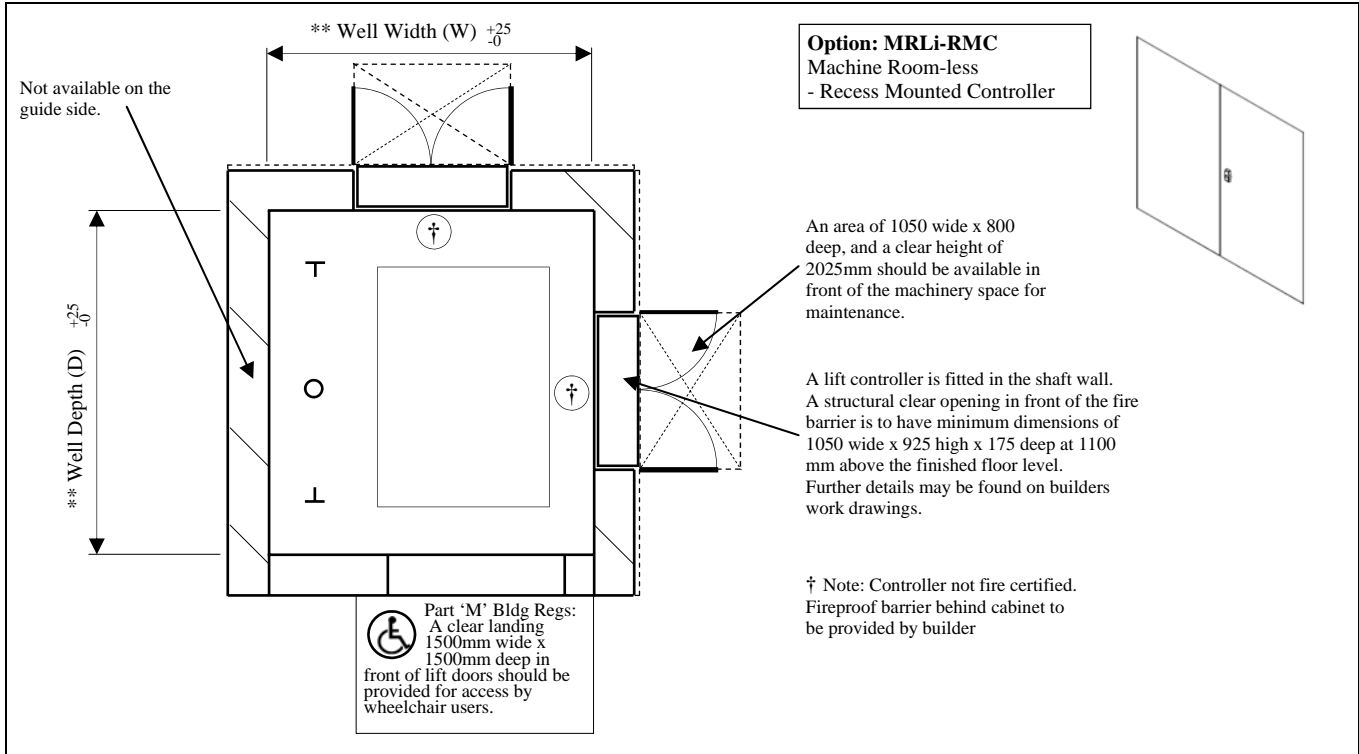

** See datasheet 10-6-1 for information on well dimensions, imposed loads and details of 10 person MRLi lifts.

Waiver:
 This data sheet is for guidance only and must not be used for proper working drawings. Please contact Stannah Lifts for particular details before proceeding. Owing to our policy of continual improvement we reserve the right to alter specifications and dimensions without prior notice.

MAXILIFT

Stannah

Machine Room-Less

Machine Room Cabinet

MRC

10 Person (800kg)

Travel: 12.8m max.
 Speed: 0.5m/s max.

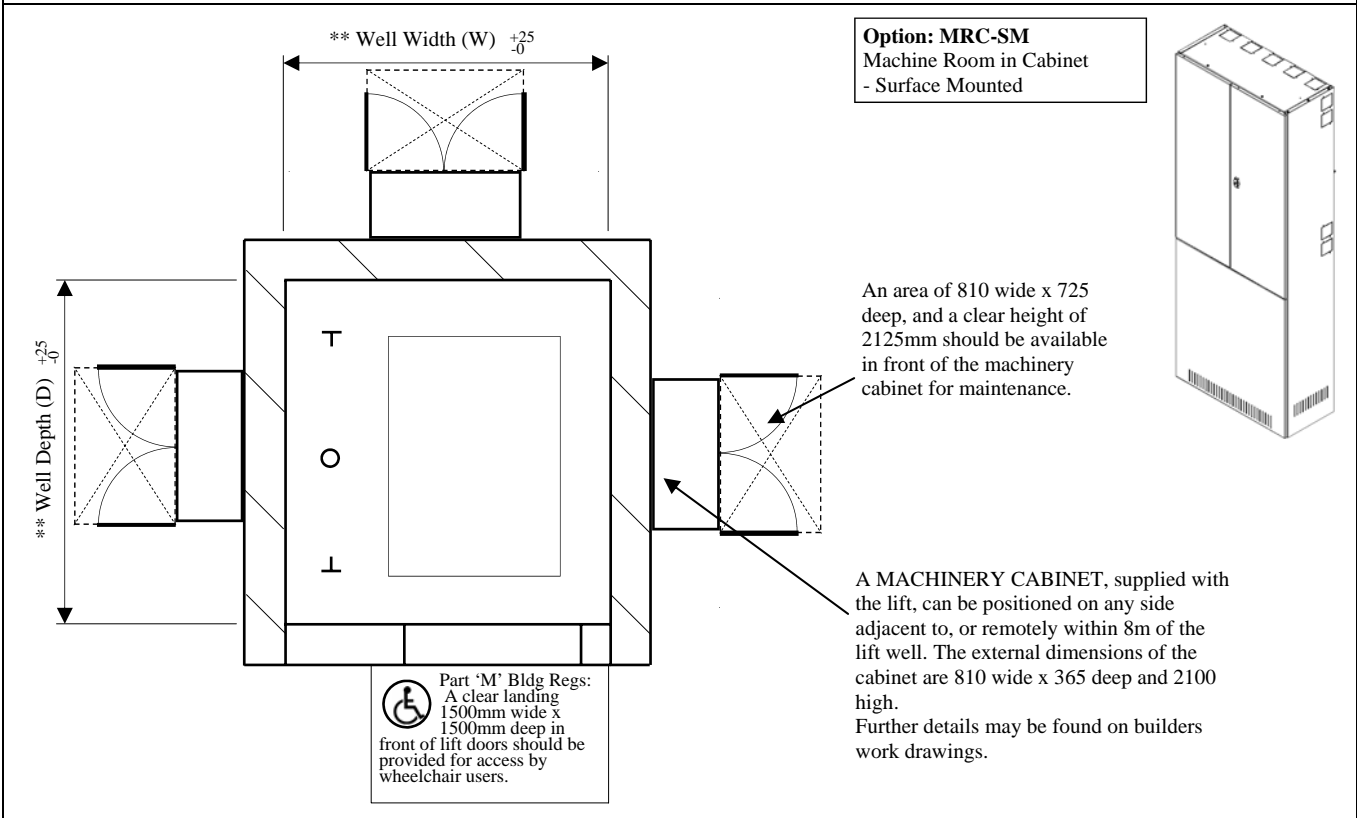
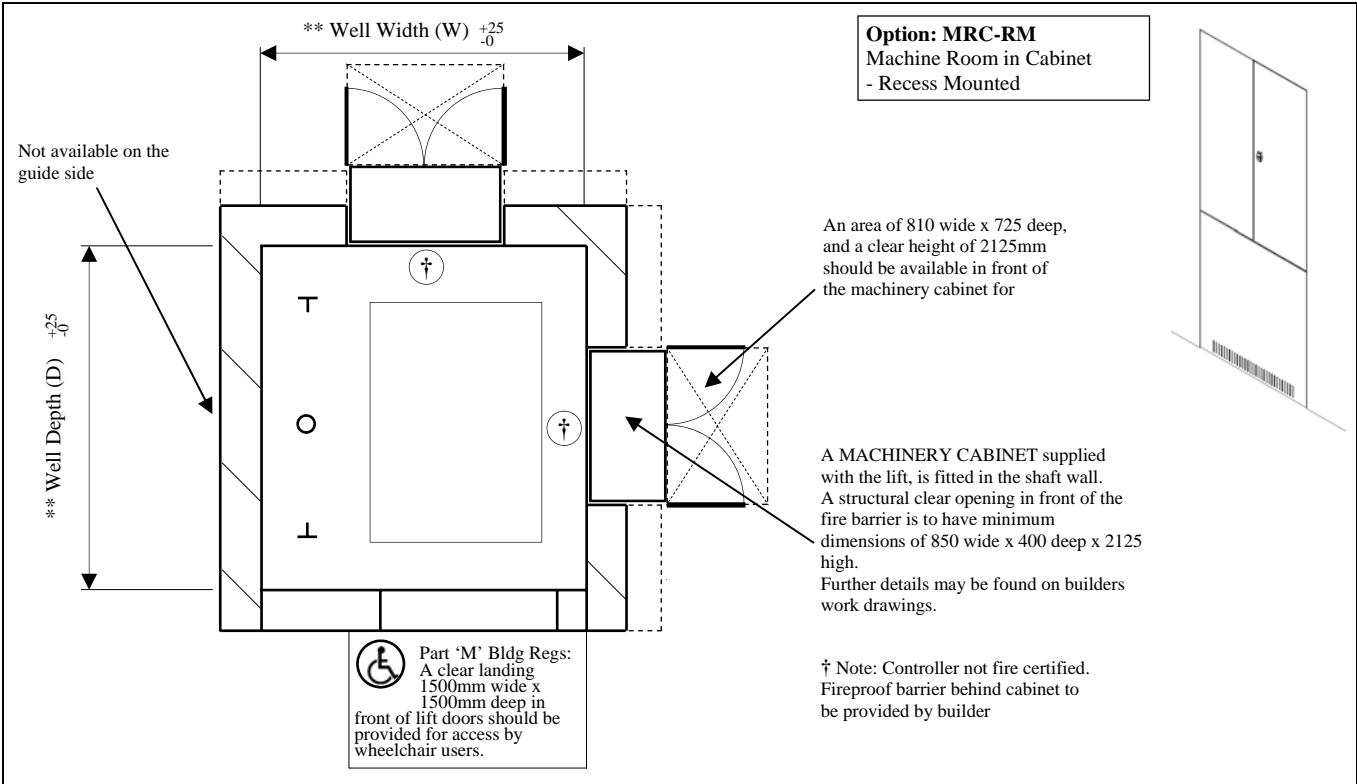

** See datasheet 10-1 for information on well dimensions, imposed loads and general details of 10 person lifts.

MAXILIFT

Hydraulic Passenger Lift Range

Stannah

Section 13

Reference

13 Person - Architects details - Stretcher	13-1
13 Person - Architects details - Square shape	13-2
Withdrawn 17/10/06	13-4
Withdrawn 17/10/06	13-5
Withdrawn 17/10/06	13-6
Withdrawn 17/10/06	13-7
13 Person - Architects details - Stretcher - MRLi	13-10-1
13 Person - Architects details - Stretcher - MRLi - Alternate Controller Locations	13-10-2
13 Person - Architects details - Square Shape - MRLi	13-11-1
13 Person - Architects details - Square Shape - MRLi - Alternate Controller Locations	13-11-2
13 Person - Architects details - Stretcher - MRC	13-12
13 Person - Architects details - Square shape - MRC	13-13

Waiver:

This data sheet is for guidance only and must not be used for proper working drawings. Please contact Stannah Lifts for particular details before proceeding. Owing to our policy of continual improvement we reserve the right to alter specifications and dimensions without prior notice.

MAXILIFT

Stannah

13 Person (1000kg) Stretcher

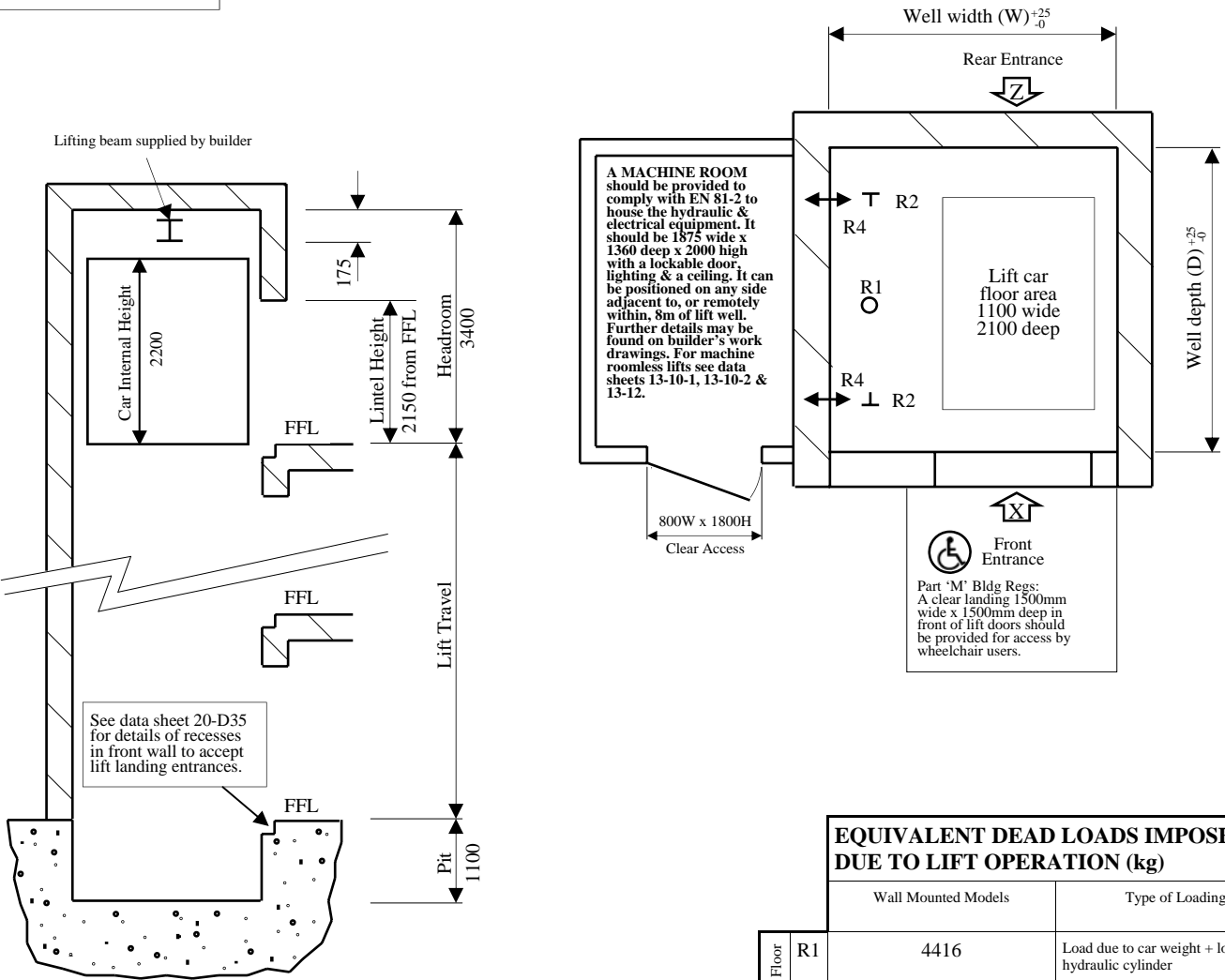

See data sheet 20-D35 for details of recesses in front wall to accept lift landing entrances.

EQUIVALENT DEAD LOADS IMPOSED DUE TO LIFT OPERATION (kg)

Side Wall	Lift Pit Floor	Type of Loading	
		Wall Mounted Models	Type of Loading
R1		4416	Load due to car weight + load + hydraulic cylinder
R2		4200	Load due to car buffering or safety gear operation
R4		439	Push in/Pull out load

IMPORTANT
On Wall Mounted Models, Unistrut inserts ref P3270 to be built into lift pit and lift well walls by builder *before* installation. See specific Builder's Work Drawings for precise details.

WALL MOUNTED MODELS

MODEL REF	LIFT DOORS ARRANGEMENT	Plan Well Dimensions				Lift Car Clear Entrance		
		Front entrance X or Z		Front & rear entrance X & Z		W	H	
		W	D	W	D			
M13-1-2S 2S (800)	Auto 2 panel side opening 2S	Auto 2 panel side opening 2S	1600	2465	1600	2710	800	2000
M13-1-2S 2S (900)	Auto 2 panel side opening 2S	Auto 2 panel side opening 2S	1700	2465	1700	2710	900	2000
M13-1-2C 2C (800)	Auto 2 panel centre opening 2C	Auto 2 panel centre opening 2C	1800	2400	1800	2580	800	2000
M13-1-2C 2C (900)	Auto 2 panel centre opening 2C	Auto 2 panel centre opening 2C	2000	2400	2000	2580	900	2000

Note: Shaft sizes are for guidance purposes only and subject to change so it is crucial that you contact Stannah concerning your specific requirements.

Note: FX model (Structure Mounted) *not* available in this capacity. Wall Mounted only.

13-1
17/06/10

Waiver:

This data sheet is for guidance only and must not be used for proper working drawings. Please contact Stannah Lifts for particular details before proceeding. Owing to our policy of continual improvement we reserve the right to alter specifications and dimensions without prior notice.

MAXILIFT

Stannah

13 Person (1000kg) Square Shape

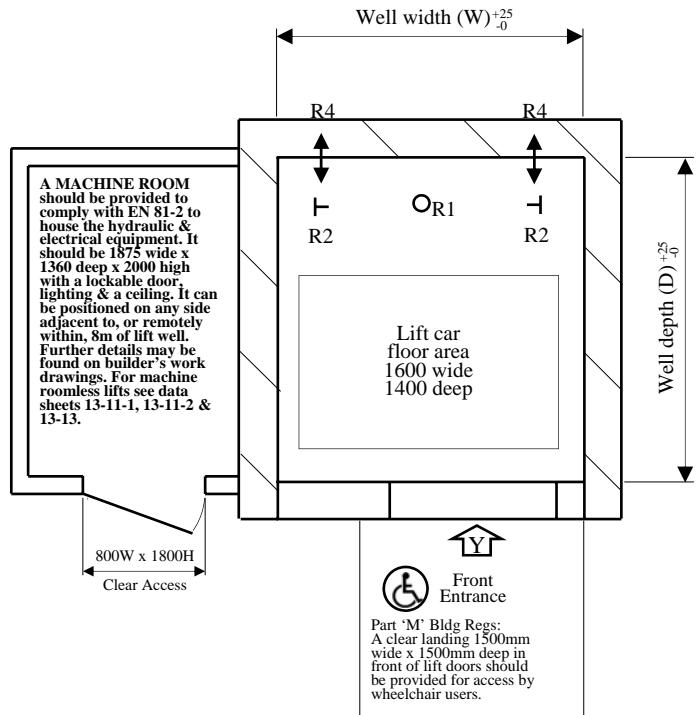
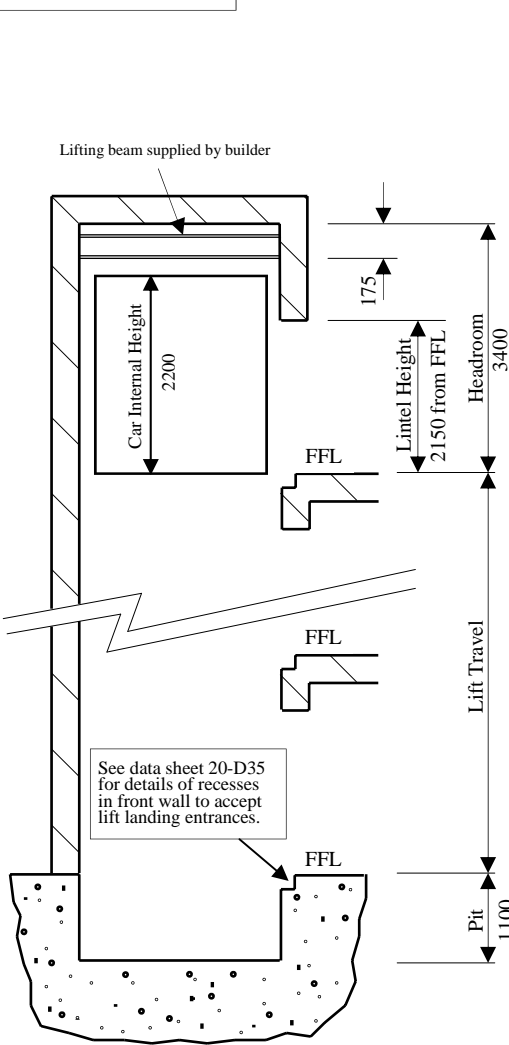

See data sheet 20-D35 for details of recesses in front wall to accept lift landing entrances.

EQUIVALENT DEAD LOADS IMPOSED DUE TO LIFT OPERATION (kg)

		Wall Mounted Models	Type of Loading
Side Wall	R1	4416	Load due to car weight + load + hydraulic cylinder
	R2	4200	Load due to car buffering or safety gear operation
	R4	529	Push in/Pull out load

IMPORTANT

On Wall Mounted Models, Unistrut inserts ref P3270 to be built into lift pit and lift well walls by builder *before* installation. See specific Builder's Work Drawings for precise details.

WALL MOUNTED MODELS

MODEL REF	LIFT DOORS ARRANGEMENT			Plan Well Dimensions				Lift Car Clear Entrance	
	Car Doors	Landing Doors	Front entrance X or Z		Front & rear entrance X & Z		W	H	
			W	D	W	D			
M13-2-2C 2C	Auto 2 panel centre opening 2C	Auto 2 panel centre opening 2C	2400	2050	Not Available	Not Available	1100	2000	

Note: Shaft sizes are for guidance purposes only and subject to change so it is crucial that you contact Stannah concerning your specific requirements.

Note: FX model (Structure Mounted) *not* available in this capacity. Wall Mounted only.

13-2
17/06/10

Waiver:
 This data sheet is for guidance only and must not be used for proper working drawings. Please contact Stannah Lifts for particular details before proceeding. Owing to our policy of continual improvement we reserve the right to alter specifications and dimensions without prior notice.

MAXILIFT

Stannah

Machine Room-Less
Totally Machine Room Free
MRLi

Option: MRLi-EC
 Machine Room-less
 - Entrance Controller

13 Person (1000kg)

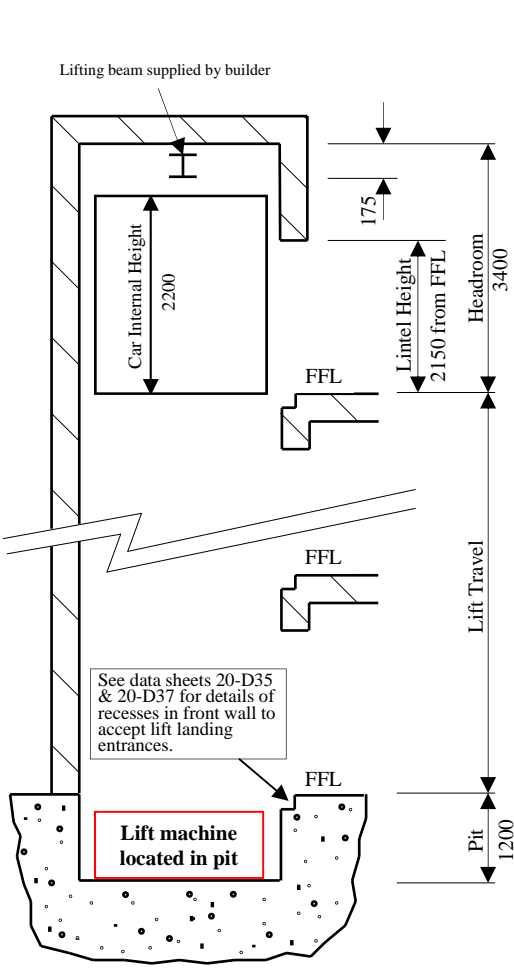

A 1hr certified lift controller forms part of the lift entrance and can be positioned at any landing (the lowest landing is preferred). See data sheet 20-D37 for cut out details. Further details may be found on builders work drawings.
 For alternative controller locations see data sheet 13-10-2

Travel: 12.3m max.
 Speed: Up to 0.5 m/s

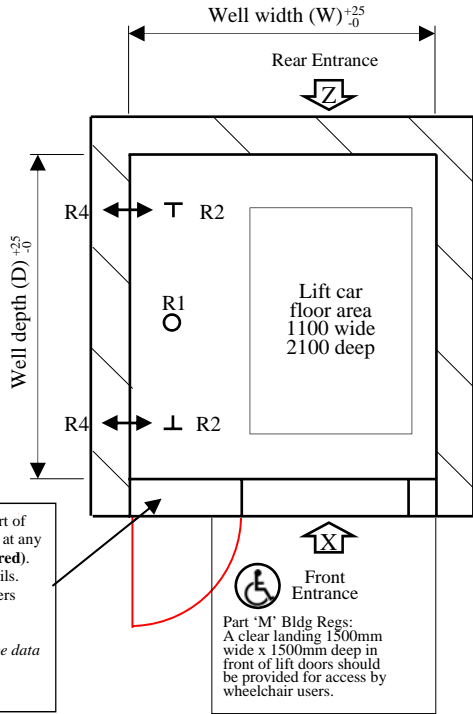

See data sheets 20-D35 & 20-D37 for details of recesses in front wall to accept lift landing entrances.

IMPORTANT
 On Wall Mounted Models, Unistrut inserts ref P3270 to be built into lift pit and lift well walls by builder before installation. See specific Builder's Work Drawings for precise details.

EQUIVALENT DEAD LOADS IMPOSED DUE TO LIFT OPERATION (kg)

	Wall Mounted Models	Type of Loading	
Side Wall Lift Pit Floor	R1	4416	Load due to car weight + load + hydraulic cylinder
	R2	4200	Load due to car buffering or safety gear operation
	R4	439	Push in/Pull out load

WALL MOUNTED MODELS

MODEL REF	LIFT DOORS ARRANGEMENT	Plan Well Dimensions				Lift Car Clear Entrance			
		Front entrance X or Z		Front & rear entrance X & Z		W	H		
		Car Doors	Landing Doors	W	D	W	D	W	H
M13-1-2S 2S (800)		Auto 2 panel side opening 2S	Auto 2 panel side opening 2S	1650	2465	1650	2710	800	2000
M13-1-2S 2S (900)		Auto 2 panel side opening 2S	Auto 2 panel side opening 2S	1750	2465	1750	2710	900	2000
M13-1-2C 2C (800)		Auto 2 panel centre opening 2C	Auto 2 panel centre opening 2C	1800	2400	1800	2580	800	2000
M13-1-2C 2C (900)		Auto 2 panel centre opening 2C	Auto 2 panel centre opening 2C	2000	2400	2000	2580	900	2000

Note: Shaft sizes are for guidance purposes only and subject to change so it is crucial that you contact Stannah concerning your specific requirements

Note: FX model (Structure Mounted) not available in this capacity. Wall Mounted only.

Machine Room-Less
 MRLi
13-10-1
 17/06/10

Waiver:
 This data sheet is for guidance only and must not be used for proper working drawings. Please contact Stannah Lifts for particular details before proceeding. Owing to our policy of continual improvement we reserve the right to alter specifications and dimensions without prior notice.

MAXILIFT

Stannah

Machine Room-Less

Alternative Controller Locations (when not desired in the landing entrance as in 13-10-1)

MRLi

13 Person (1000kg) Stretcher

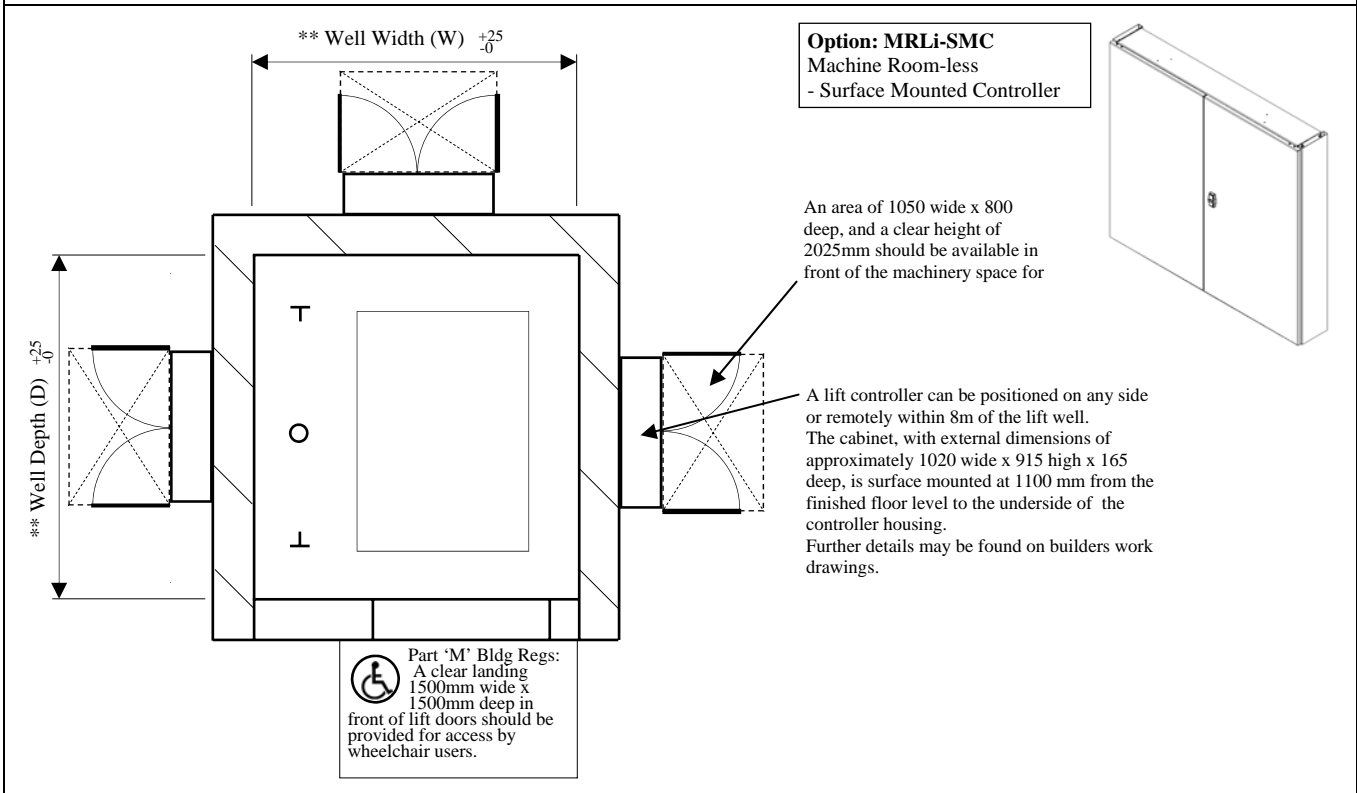
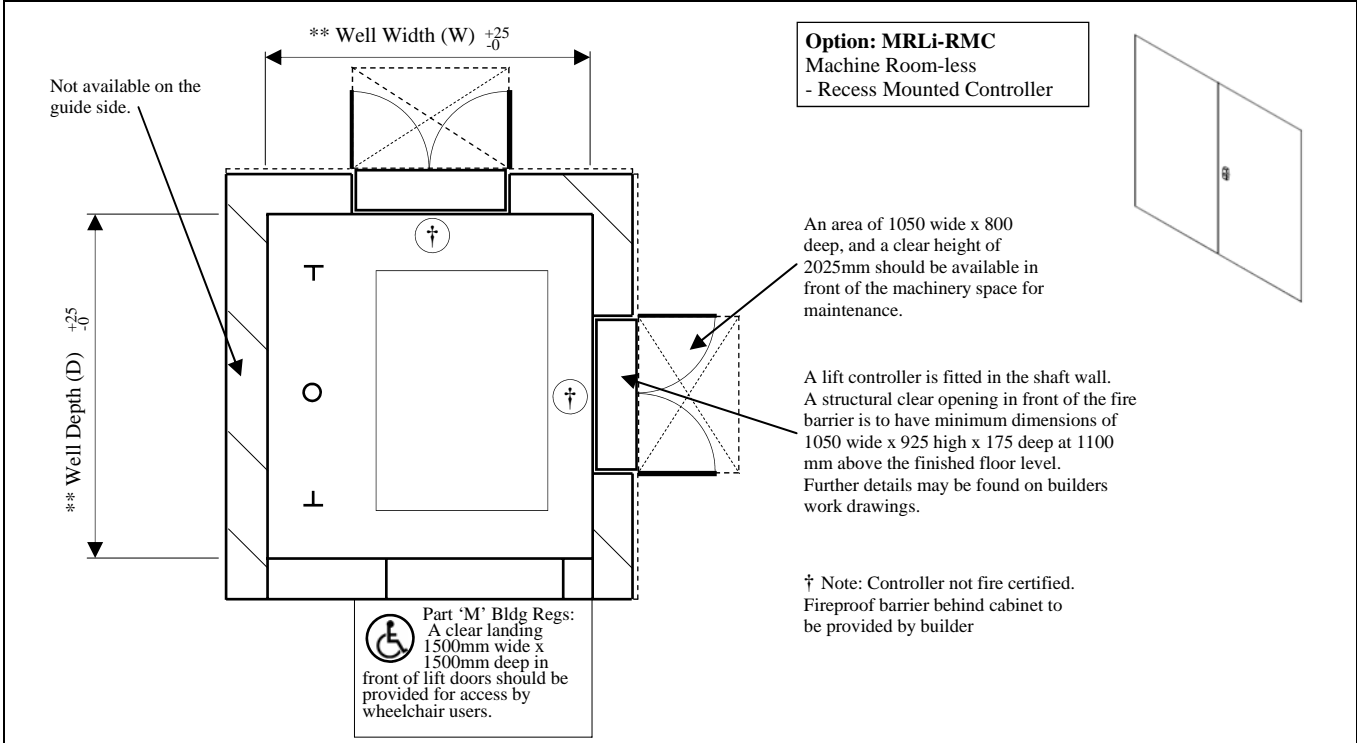

** See datasheet 13-10-1 for information on well dimensions, imposed loads and details of 13 person (stretcher) MRLi lifts.

Waiver:

This data sheet is for guidance only and must not be used for proper working drawings. Please contact Stannah Lifts for particular details before proceeding. Owing to our policy of continual improvement we reserve the right to alter specifications and dimensions without prior notice.

MAXILIFT

Stannah

**Machine Room-Less
Totally Machine Room Free**

Option: MRLi-EC
Machine Room-less
- Entrance Controller

MRLi

13 Person (1000kg)

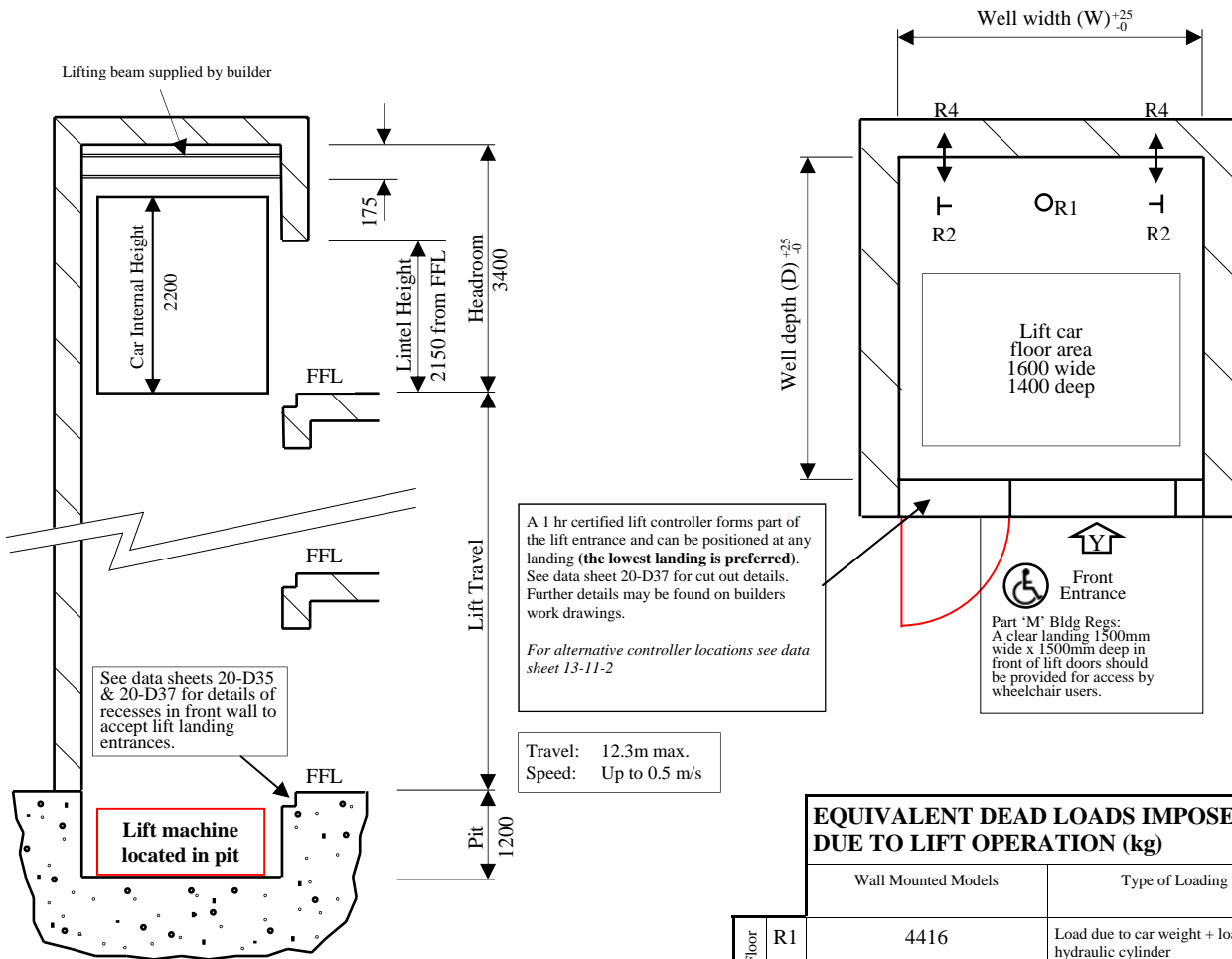

See data sheets 20-D35 & 20-D37 for details of recesses in front wall to accept lift landing entrances.

A 1 hr certified lift controller forms part of the lift entrance and can be positioned at any landing (the lowest landing is preferred). See data sheet 20-D37 for cut out details. Further details may be found on builders work drawings.
For alternative controller locations see data sheet 13-11-2

Travel: 12.3m max.
Speed: Up to 0.5 m/s

EQUIVALENT DEAD LOADS IMPOSED DUE TO LIFT OPERATION (kg)

		Wall Mounted Models	Type of Loading	
Side Wall	Lift Pit Floor	R1	4416	Load due to car weight + load + hydraulic cylinder
		R2	4200	Load due to car buffering or safety gear operation
		R4	529	Push in/Pull out load

IMPORTANT

On Wall Mounted Models, Unistrut inserts ref P3270 to be built into lift pit and lift well walls by builder *before* installation. See specific Builder's Work Drawings for precise details.

WALL MOUNTED MODELS

MODEL REF	LIFT DOORS ARRANGEMENT			Plan Well Dimensions				Lift Car Clear Entrance	
	Car Doors	Landing Doors	Diagram	Front entrance X or Z		Front & rear entrance X & Z		W	H
				W	D	W	D		
M13-2-2C 2C	Auto 2 panel centre opening 2C	Auto 2 panel centre opening 2C		2400	2050	Not Available	Not Available	1100	2000

Note: Shaft sizes are for guidance purposes only and subject to change so it is crucial that you contact Stannah concerning your specific requirements

Note: FX model (Structure Mounted) *not* available in this capacity. Wall Mounted only.

**Machine Room-Less
MRLi
13-11-1
17/06/10**

Waiver:

This data sheet is for guidance only and must not be used for proper working drawings. Please contact Stannah Lifts for particular details before proceeding. Owing to our policy of continual improvement we reserve the right to alter specifications and dimensions without prior notice.

MAXILIFT

Stannah

Machine Room-Less

Alternative Controller Locations (when not desired in the landing entrance as in 13-11-1)

MRLi

13 Person (1000kg) Square Shape

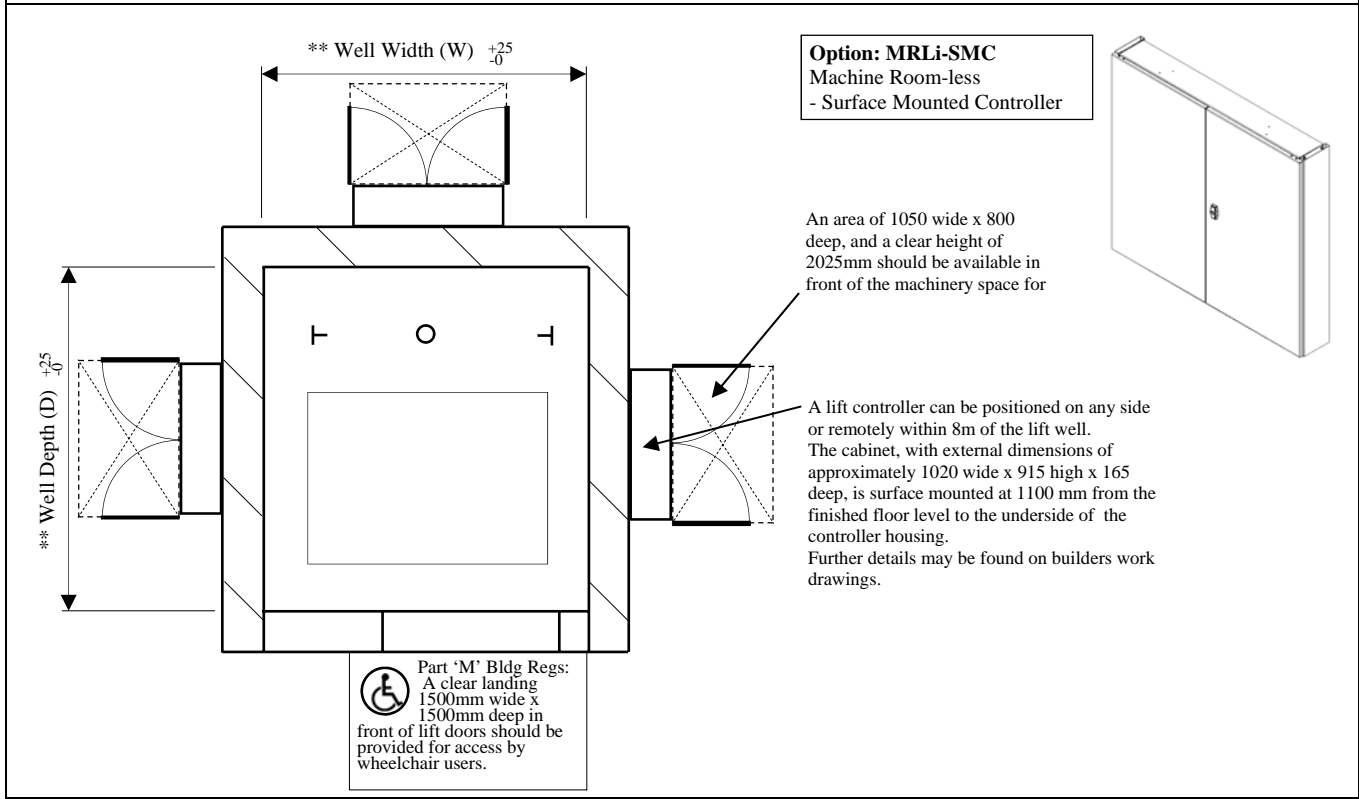
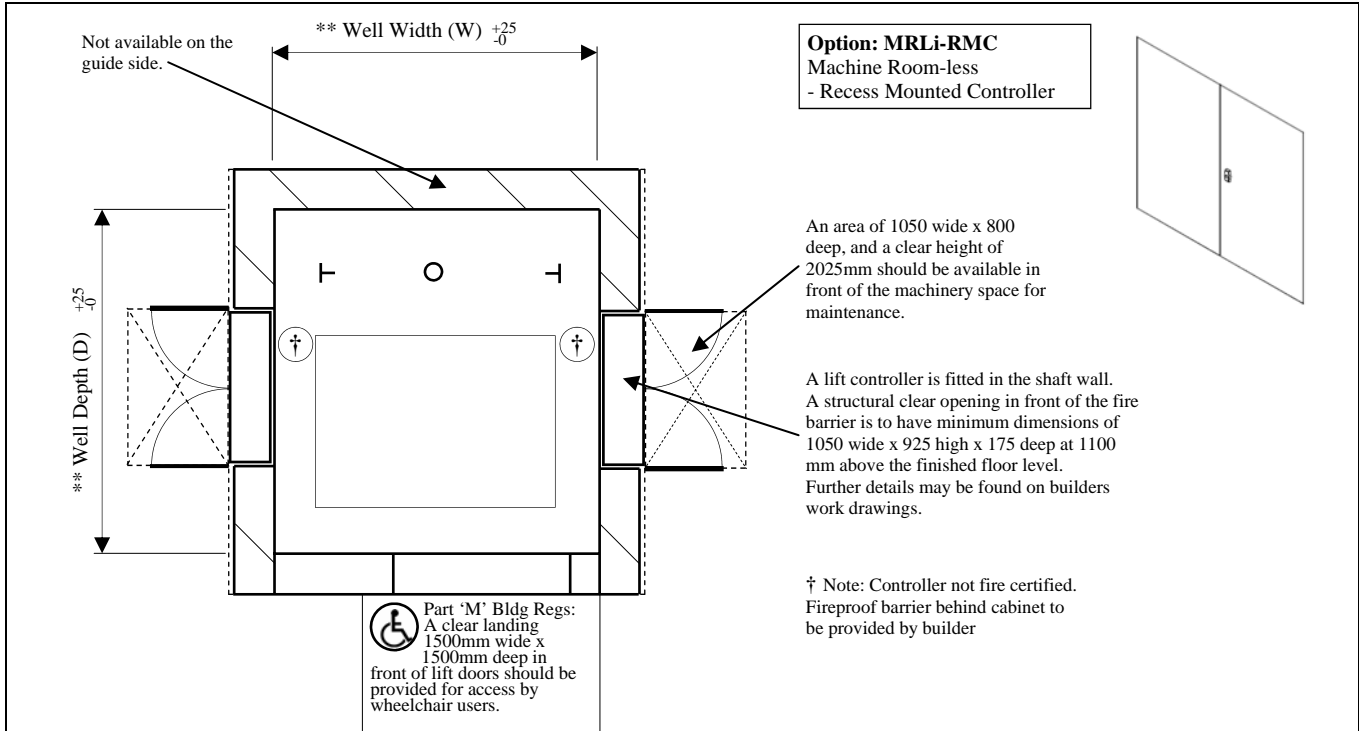

** See datasheet 13-11-1 for information on well dimensions, imposed loads and details of 13 person (square shape) MRLi lifts.

Waiver:

This data sheet is for guidance only and must not be used for proper working drawings. Please contact Stannah Lifts for particular details before proceeding. Owing to our policy of continual improvement we reserve the right to alter specifications and dimensions without prior notice.

MAXILIFT

Stannah

Machine Room-Less

Machine Room Cabinet

MRC

Travel: 10.7m max.
Speed: 0.4m/s max.

13 Person (1000kg) Stretcher

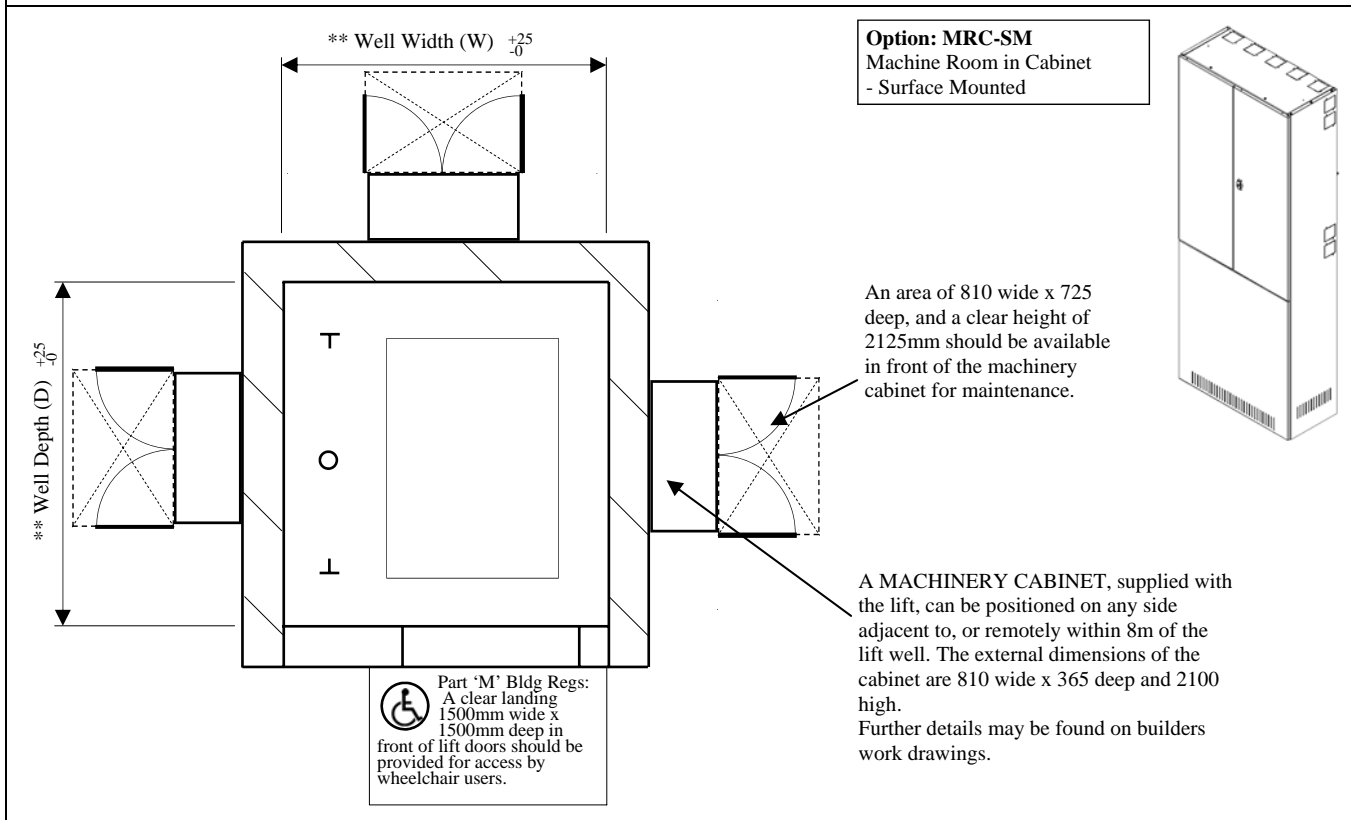
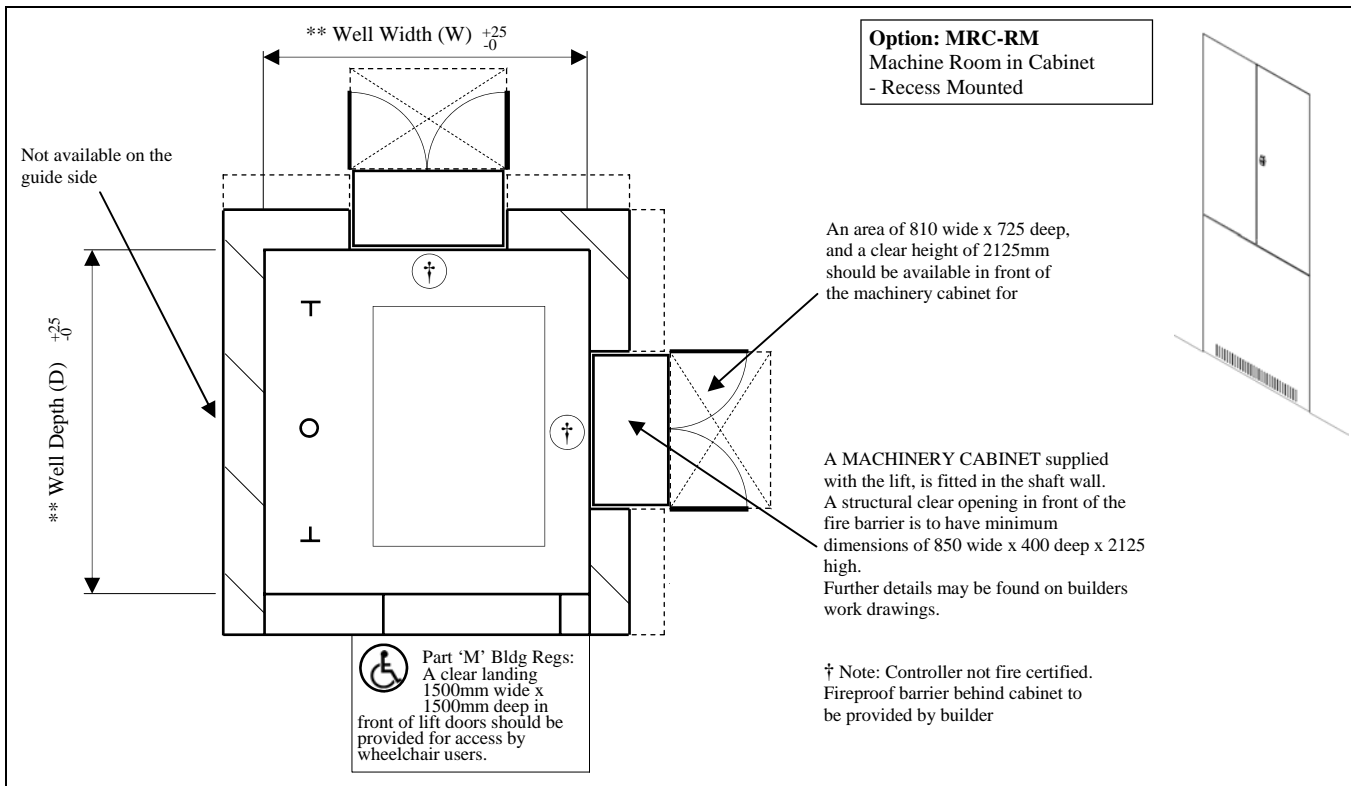

** See datasheet 13-1 for information on well dimensions, imposed loads and general details of 13 person (stretcher) lifts.

Waiver:
 This data sheet is for guidance only and must not be used for proper working drawings. Please contact Stannah Lifts for particular details before proceeding. Owing to our policy of continual improvement we reserve the right to alter specifications and dimensions without prior notice.

MAXILIFT

Stannah

Machine Room-Less

Machine Room Cabinet

MRC

Travel: 10.7m max.
 Speed: 0.4m/s max.

13 Person (1000kg) Square Shape

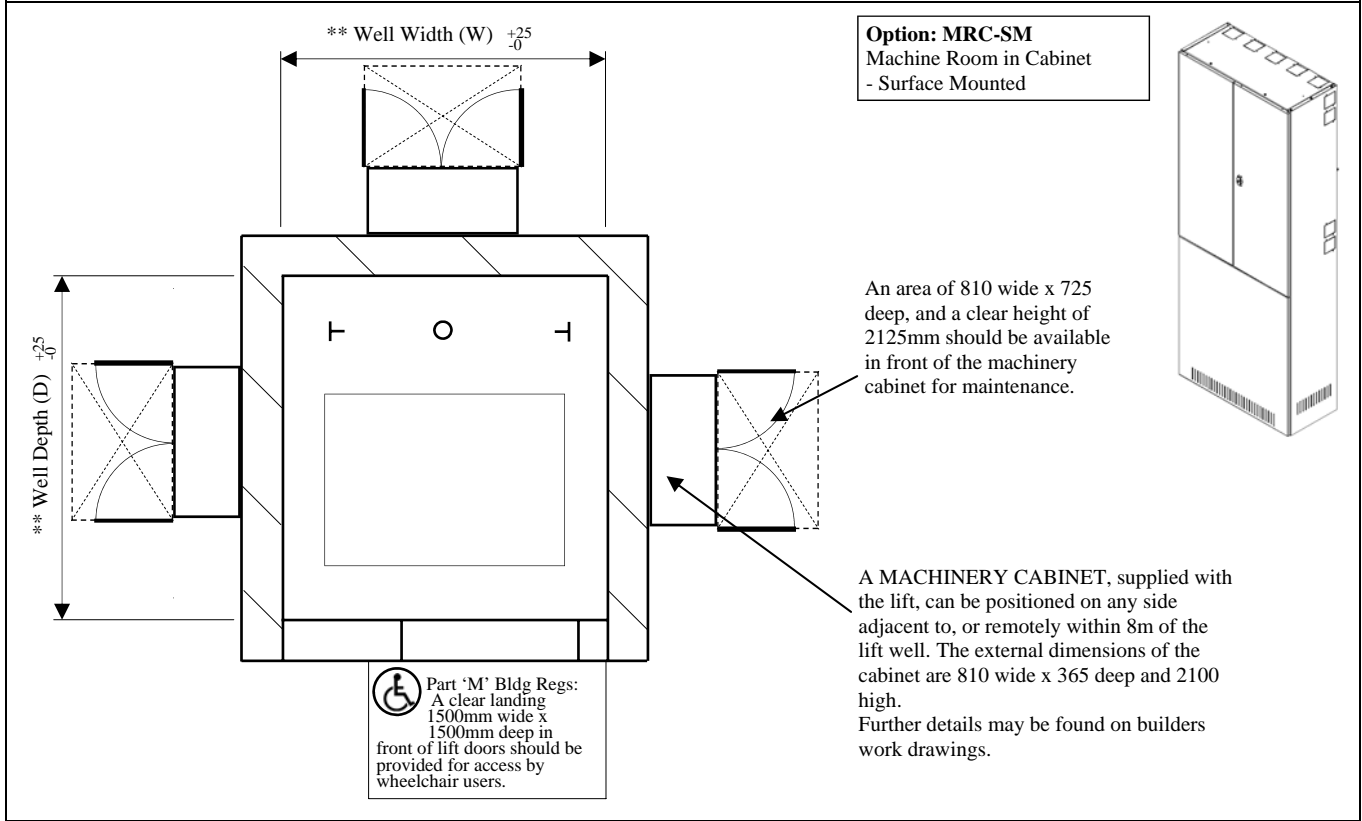
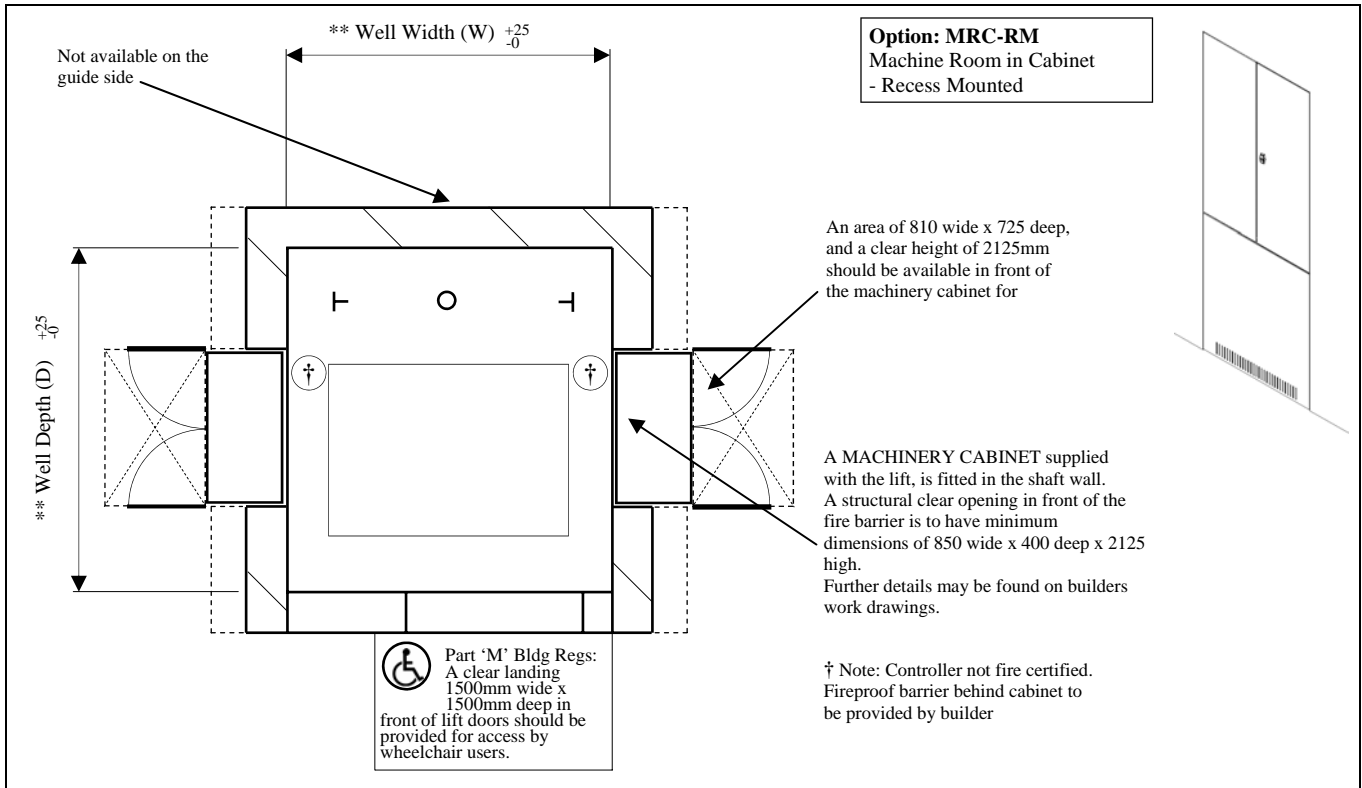

** See datasheet 13-2 for information on well dimensions, imposed loads and general details of 13 person (square shape) lifts.

MAXILIFT

Hydraulic Passenger Lift Range

Stannah

Section 16

Reference

16 Person - Architects details	16-1
16 Person - Architects details - MRLi	16-2
16 Person - Architects details - Alternate Controller Locations	16-3
16 Person - Architects details - MRC	16-4

Waiver:
 This data sheet is for guidance only and must not be used for proper working drawings. Please contact Stannah Lifts for particular details before proceeding. Owing to our policy of continual improvement we reserve the right to alter specifications and dimensions without prior notice.

MAXILIFT

Stannah

16 Person (1200kg)

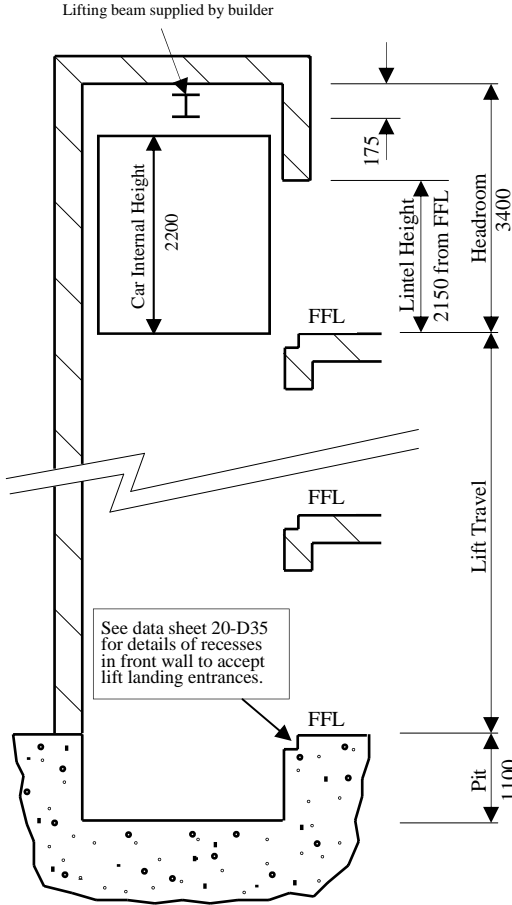

See data sheet 20-D35 for details of recesses in front wall to accept lift landing entrances.

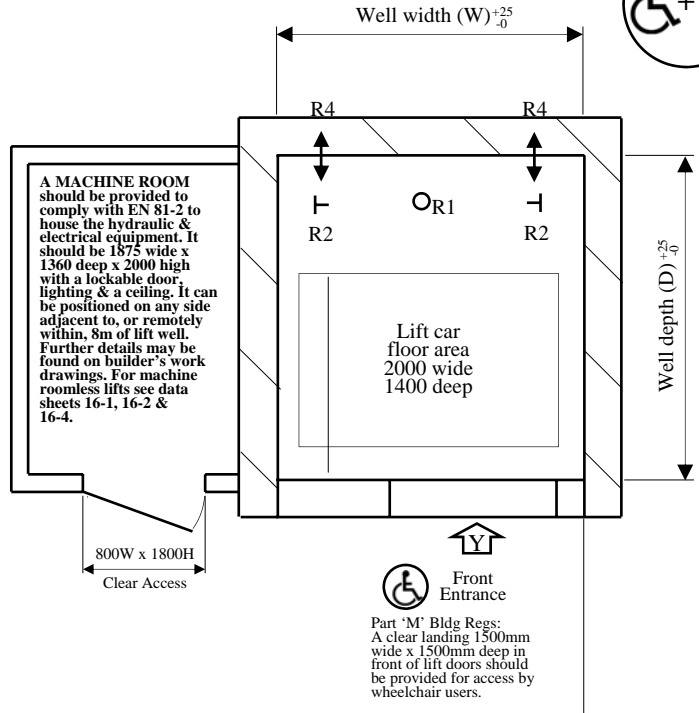

A MACHINE ROOM should be provided to comply with EN 81-2 to house the hydraulic & electrical equipment. It should be 1875 wide x 1360 deep x 2000 high with a lockable door, lighting & a ceiling. It can be positioned on any side adjacent to, or remotely within, 8m of lift well. Further details may be found on builder's work drawings. For machine roomless lifts see data sheets 16-1, 16-2 & 16-4.

Part 'M' Bldg Regs: A clear landing 1500mm wide x 1500mm deep in front of lift doors should be provided for access by wheelchair users.

IMPORTANT
 On Wall Mounted Models, Unistrut inserts ref P3270 to be built into lift pit and lift well walls by builder *before* installation. See specific Builder's Work Drawings for precise details.

EQUIVALENT DEAD LOADS IMPOSED DUE TO LIFT OPERATION (kg)

Side Wall	Lift Pit Floor	Type of Loading	
		Wall Mounted Models	Type of Loading
	R1	4929	Load due to car weight + load + hydraulic cylinder
	R2	4890	Load due to car buffering or safety gear operation
	R4	647	Push in/Pull out load

MODEL REF	LIFT DOORS ARRANGEMENT	WALL MOUNTED MODELS					
		LIFT DOORS ARRANGEMENT		Plan Well Dimensions		Lift Car Clear Entrance	
		Car Doors	Landing Doors	W	D	W	H
M16 - 2C - 2C	Auto 2 panel centre opening 2C	Auto 2 panel centre opening 2C	2400.0	2000.0	1100.0	2000.0	

Note: Shaft sizes are for guidance purposes only and subject to change so it is crucial that you contact Stannah concerning your specific requirements.

Note: FX model (Structure Mounted) *not* available in this capacity. Wall Mounted only.

16-1
 17/06/10

Waiver:
 This data sheet is for guidance only and must not be used for proper working drawings. Please contact Stannah Lifts for particular details before proceeding. Owing to our policy of continual improvement we reserve the right to alter specifications and dimensions without prior notice.

MAXILIFT

Stannah

Machine Room-Less Totally Machine Room Free

Option: MRLi-EC
 Machine Room-less
 - Entrance Controller

MRLi

16

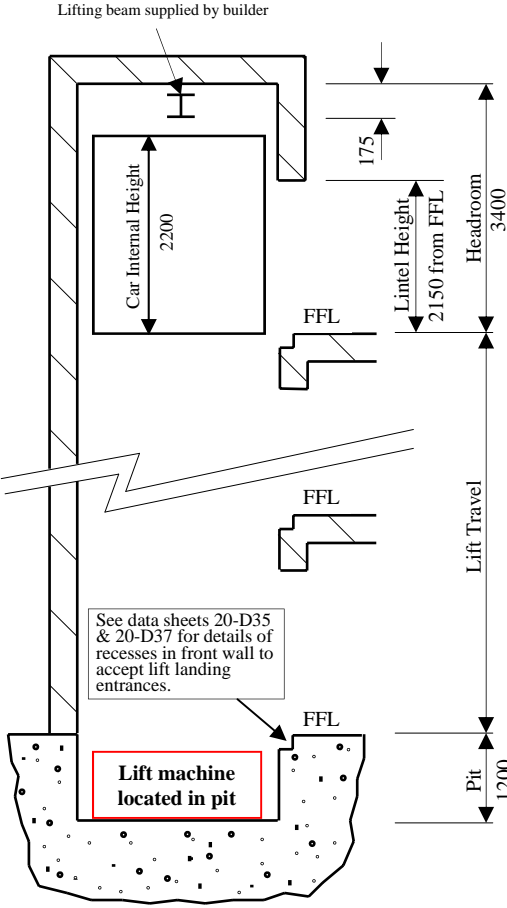

A 1 hr certified lift controller forms part of the lift entrance and can be positioned at any landing (**the lowest landing is preferred**). See data sheet 20-D37 for cut out details. Further details may be found on builders work drawings.
 For alternative controller locations see data sheet 16-3

Travel: 9.00m max.
 Speed: Up to 0.4 m/s

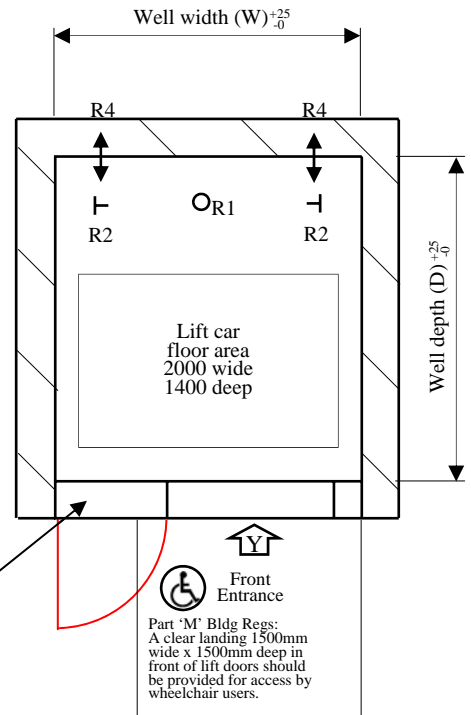

See data sheets 20-D35 & 20-D37 for details of recesses in front wall to accept lift landing entrances.

EQUIVALENT DEAD LOADS IMPOSED DUE TO LIFT OPERATION (kg)

Side Wall Lift Pit/Floor	Wall Mounted Models		Type of Loading	
	R1	R2	R4	
R1	4929		Load due to car weight + load + hydraulic cylinder	
R2		4890	Load due to car buffering or safety gear operation	
R4			647	Push in/Pull out load

IMPORTANT

On Wall Mounted Models, Unistrut inserts ref P3270 to be built into lift pit and lift well walls by builder *before* installation. See specific Builder's Work Drawings for precise details.

WALL MOUNTED MODELS

MODEL REF	LIFT DOORS ARRANGEMENT		Plan Well Dimensions Y		Lift Car Clear Entrance	
	Car Doors	Landing Doors	W	D	W	H
M16 - 2C - 2C		Auto 2 panel centre opening 2C	2400.0	2000.0	1100.0	2000.0

Note: Shaft sizes are for guidance purposes only and subject to change so it is crucial that you contact Stannah concerning your specific requirements.

Note: FX model (Structure Mounted) *not* available in this capacity. Wall Mounted only.

Machine Room-Less
 MRLi
16-2
 17/06/10

Waiver:

This data sheet is for guidance only and must not be used for proper working drawings. Please contact Stannah Lifts for particular details before proceeding. Owing to our policy of continual improvement we reserve the right to alter specifications and dimensions without prior notice.

MAXILIFT

Stannah

Machine Room-Less

Alternative Controller Locations (when not desired in the landing entrance as in 16-2)

MRLi

16 Person (1200kg)

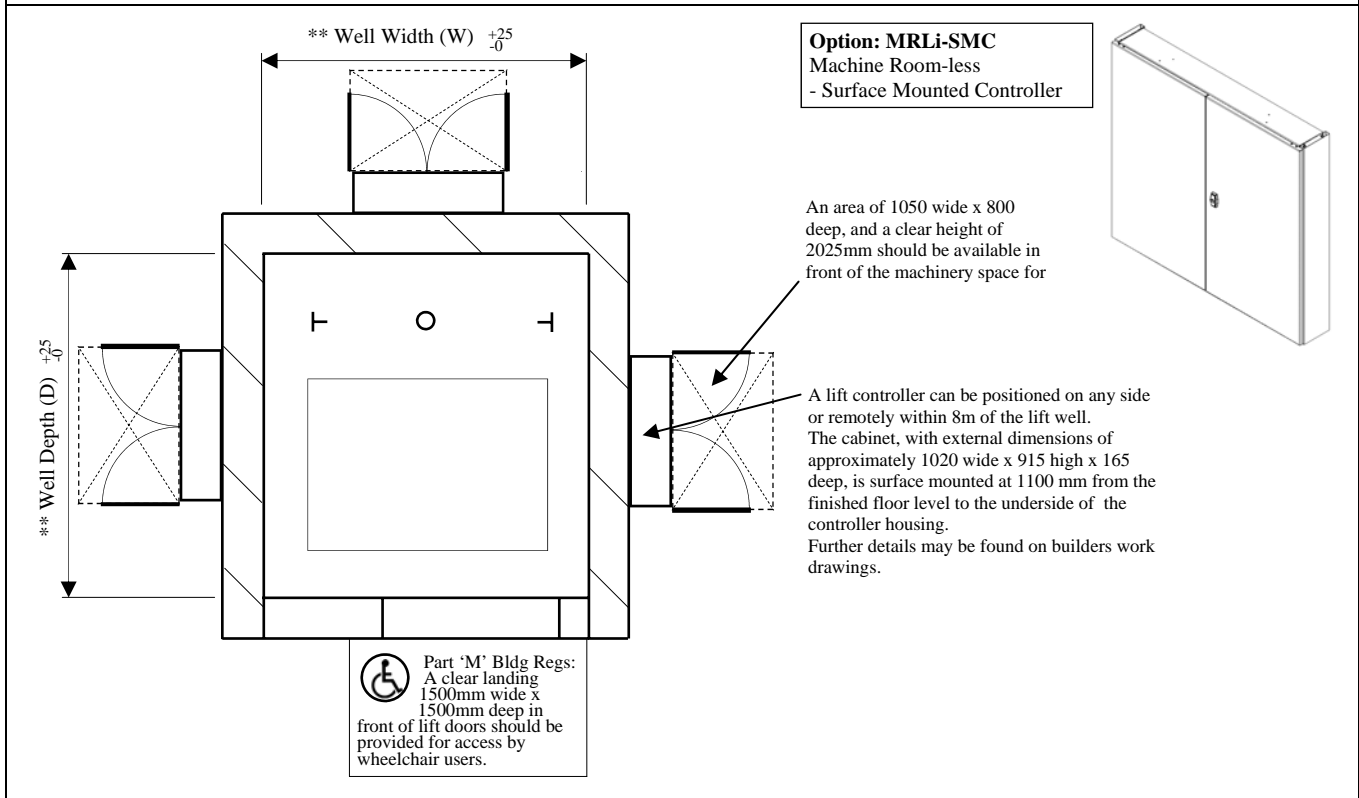
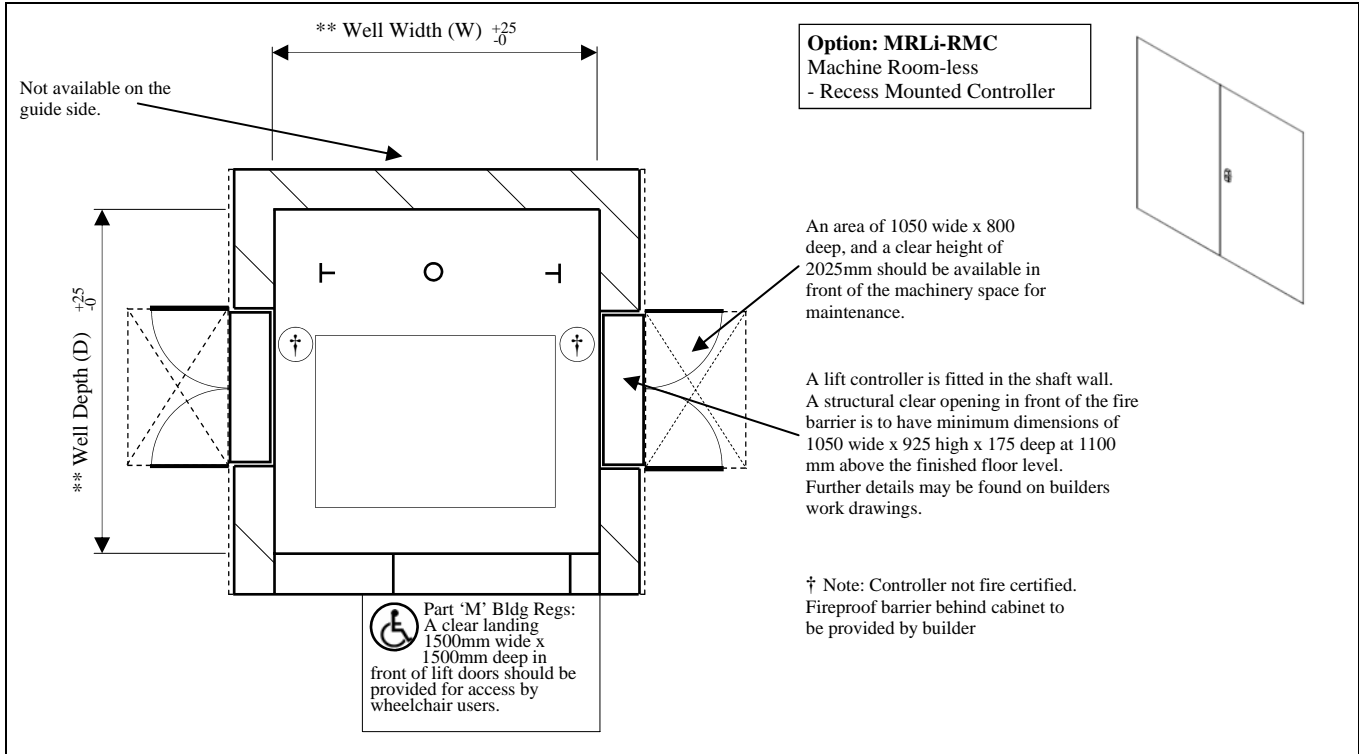

** See datasheet 16-2 for information on well dimensions, imposed loads and details of 16 person MRLi lifts.

Waiver:

This data sheet is for guidance only and must not be used for proper working drawings. Please contact Stannah Lifts for particular details before proceeding. Owing to our policy of continual improvement we reserve the right to alter specifications and dimensions without prior notice.

MAXILIFT

Stannah

Machine Room-Less

Machine Room Cabinet

MRC

16 Person (1200kg)

Travel: 7.80m max.
Speed: 0.3m/s max.

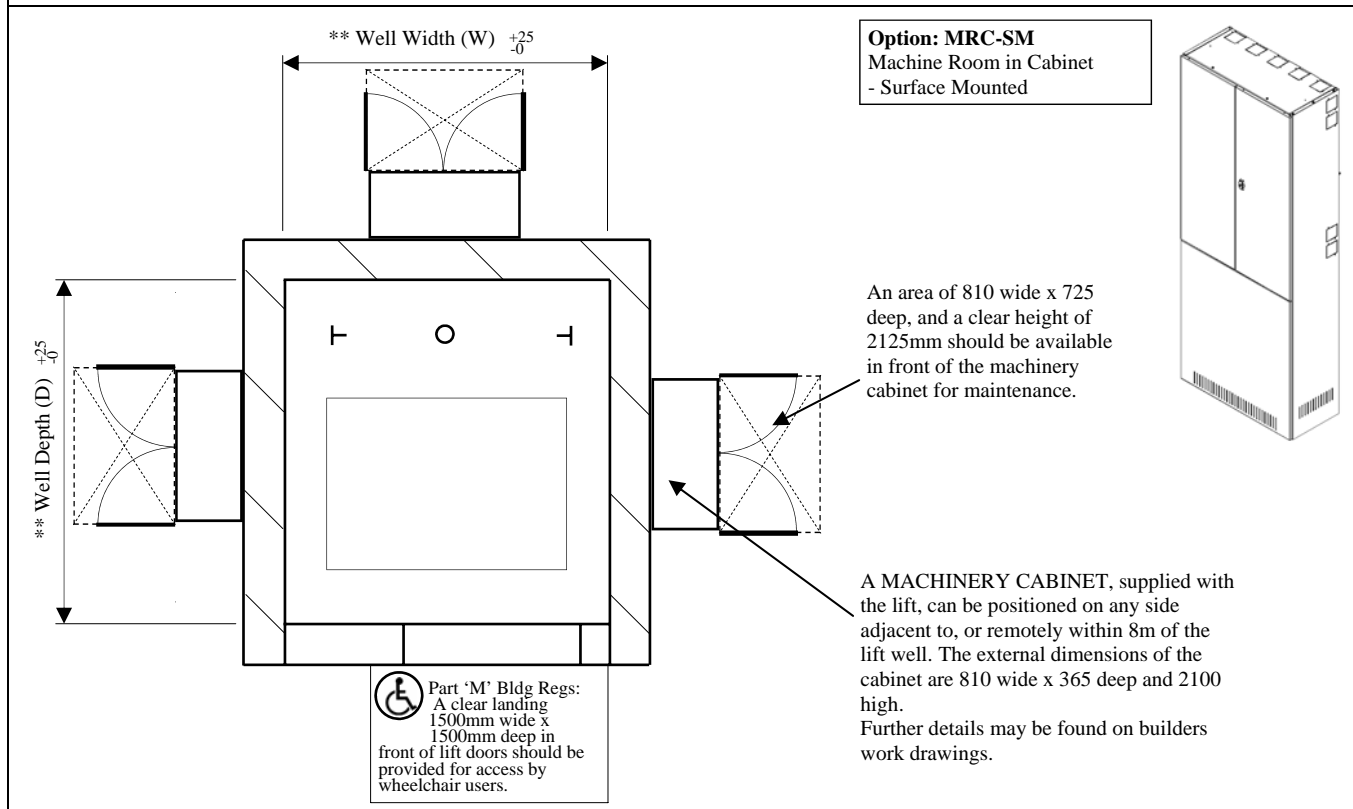
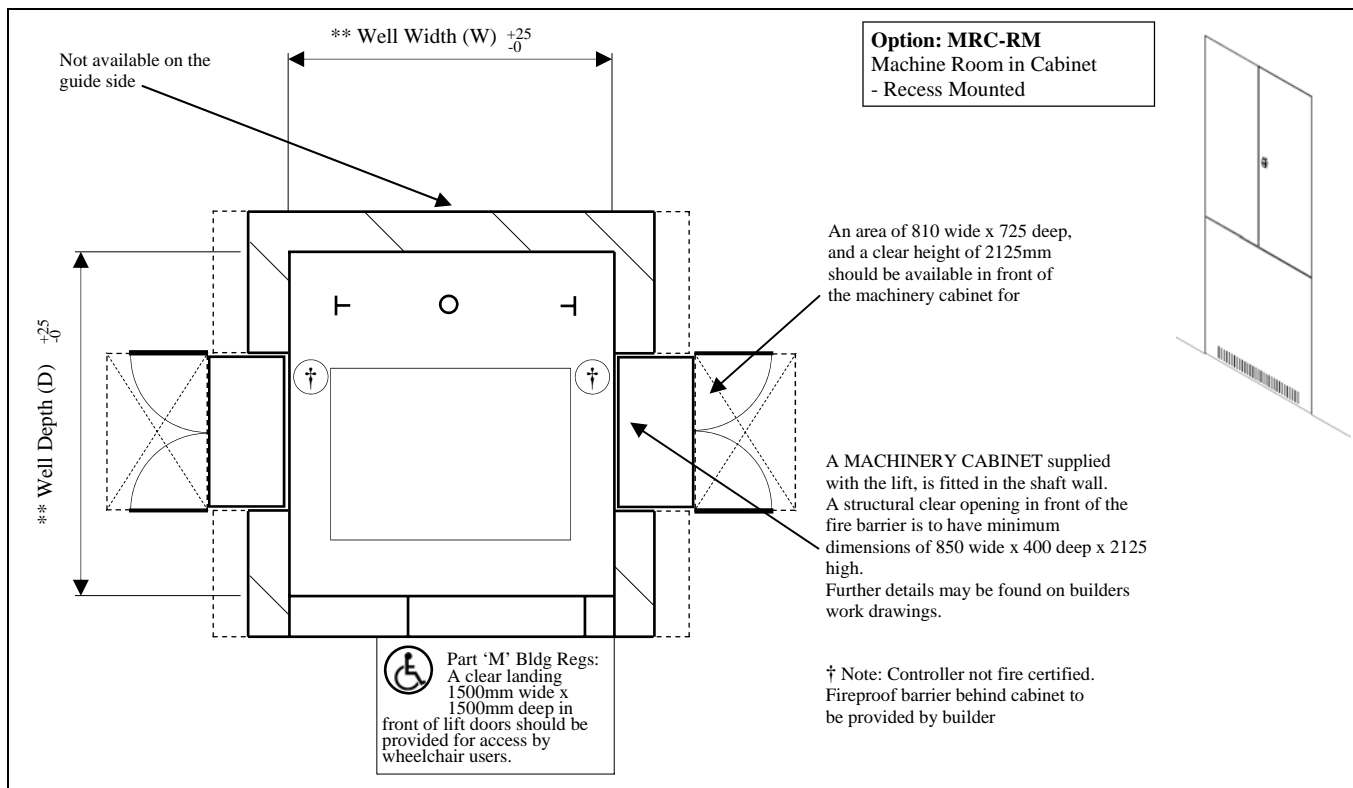

** See datasheet 16-1 for information on well dimensions, imposed loads and general details of 16 person lifts.

Hydraulic Passenger Lift Range

Section 20

Reference

Sales data sheets - Table of Contents	20-D0
Minimum pit depth	20-D1
Minimum pit depth	20-D1-1
Headroom dimensions - Indirect	20-D2
Headroom dimensions - Direct	20-D3
Hydraulic Specification - 6 Person Maxilift	20-D7
Hydraulic Specification - 8 Person Maxilift	20-D8
Hydraulic Specification - 10 Person Maxilift	20-D9
Hydraulic Specification - 13 Person Maxilift	20-D10
Electrical Requirements by Electrical Contractor	20-D11
Electrical Current Loadings and Fuse Ratings	20-D12
Lift Pit Information - Pit Foothole Details	20-D13
Lift Pit Information - WM Models Single Entrance Details	20-D14
Lift Pit Information - WM Models Through Entrance Details	20-D15
Landing Entrance Arrangement - Automatic Two Panel Side Opening	20-D17
Landing Entrance Arrangement - Automatic Two Panel Centre Opening	20-D18
Electrical Requirements for MRC-SM or MRC-RM	20-D21
MRC Electrical Capabilities	20-D26
Electrical Requirements by Electrical Contractor for MRC	20-D27
Current Loadings and Fuse Ratings for MRC	20-D28
Maxilift Noise Levels	20-D29
MRC Oil Cooler Option	20-D30
Hydraulics Selection	20-D31
Hydraulic Specification - 8 Person MRLi (Maxilift)	20-D32
Hydraulic Specification - 10 Person MRLi (Maxilift)	20-D33
Hydraulic Specification - 13 Person MRLi (Maxilift)	20-D34
Landing Entrance Cut-Out Details	20-D35
Withdrawn 09/08/06	20-D36
Landing Entrance Cut-Out Details - MRLi	20-D37
Hydraulic Specification - 16 Person (Maxilift)	20-D38
Hydraulic Specification - 16 Person MRLi (Maxilift)	20-D39

Sales Data Sheets Table of Contents

Data Sheet No.	Description	Models				
		6 person	8 person	10 person	13 person	16 person
20-D1	Minimum Pit Depth	✓	✓	✓	✓	✓
20-D2	Headroom dimensions - Indirect (2:1)	✓	✓	✓	✓	✓
20-D3	Pit and Headroom dimensions - Direct (1:1)	✓	✓	✓	✓	✓
20-D7	Hydraulic Specifications - 6 Person Maxilift	✓				
20-D8	Hydraulic Specifications - 8 Person Maxilift		✓			
20-D9	Hydraulic Specifications - 10 Person Maxilift			✓		
20-D10	Hydraulic Specifications - 13 Person Maxilift				✓	
20-D11	Electrical Requirements by Electrical Contractor	✓	✓	✓	✓	✓
20-D12	Electrical Current Loadings and Fuse Ratings	✓	✓	✓	✓	✓
20-D13	Lift Pit Information - Pit Foothole Details	✓	✓	✓	✓	✓
20-D14	Lift Pit Information - WM Models Single Entrance Details	✓	✓	✓	✓	✓
20-D15	Lift Pit Information - WM Models Through Entrance Details	✓	✓	✓	✓ M13-1 Only	
20-D17	Landing Entrance Arrangement - Automatic Two Panel Side Opening	✓	✓	✓	✓	✓
20-D18	Landing Entrance Arrangement - Automatic Two Panel Centre Opening		✓	✓	✓	✓
20-D21	Electrical Requirements for MRC-SM or MRC-RM	MRC only	MRC only	MRC only	MRC only	MRC only
20-D26	MRC Electrical Capabilities	MRC only	MRC only	MRC only	MRC only	MRC only
20-D27	Electrical Requirements by Electrical Contractor for MRC	MRC only	MRC only	MRC only	MRC only	MRC only
20-D28	Current Loadings and Fuse Ratings for MRC	MRC only	MRC only	MRC only	MRC only	MRC only
20-D29	Maxilift Noise Levels	✓	✓	✓	✓	✓
20-D30	MRC Oil Cooler Option	MRC only	MRC only	MRC only	MRC only	MRC only
20-D31	Hydraulics Selection	✓	✓	✓	✓	✓
20-D32	Hydraulic Specifications - 8 Person MRLi		MRLi only			
20-D33	Hydraulic Specifications - 10 Person MRLi			MRLi only		
20-D34	Hydraulic Specifications - 13 Person MRLi				MRLi only	

Sales Data Sheets Table of Contents - Continued

Data Sheet No.	Description	Models				
		6 person	8 person	10 person	13 person	16 person
20-D35	Landing Entrance Cut-Out Details	✓	✓	✓	✓	✓
20-D37	Landing Entrance Cut-Out Details MRLi		✓	✓	✓	✓
20-D38	Hydraulic Specification - 16 Person (Maxilift)					✓
20-D39	Hydraulic Specification - 16 Person MRLi (Maxilift)					MRLi only

Waiver:

This data sheet is for guidance only and must not be used for proper working drawings. Please contact Stannah Lifts for particular details before proceeding. Owing to our policy of continual improvement we reserve the right to alter specifications and dimensions without prior notice.

MAXILIFT

Arrangement for Minimum Pit Depth

Stannah

Model	PDO Type	Sling Type	Standard Pit	Minimum pit with Design Examination	Minimum Pit EN81-2
6 Person	2PSO	Direct	1100	1009	1025
		Tackle	1100	1070	1070
8 Person	2PSO	Direct	1100	991	1025
		Tackle	1100	993	1070
	2PSO Adjacent	Direct	1100	991	1025
		Tackle	1100	993	1070
2PCO	Direct	1100	970	1025	
	Tackle	1100	970	1070	
10 Person	2PCO	Direct	1100	870	1025
		Tackle	1100	870	1070
13 Person Stretcher	2PSO	Direct	1100	870	1025
		Tackle	1100	994	1070
	2PCO	Direct	1100	820	1025
		Tackle	1100	820	1070
13 Person Com.	2PCO	Direct	1100	870	1025
		Tackle	1100	870	1070
16 Person	2PCO	Direct	1100	870	1025
		Tackle	1100	980	1070

Note: For pit depths specific to MRLi lifts, refer datasheet 20-D1-1

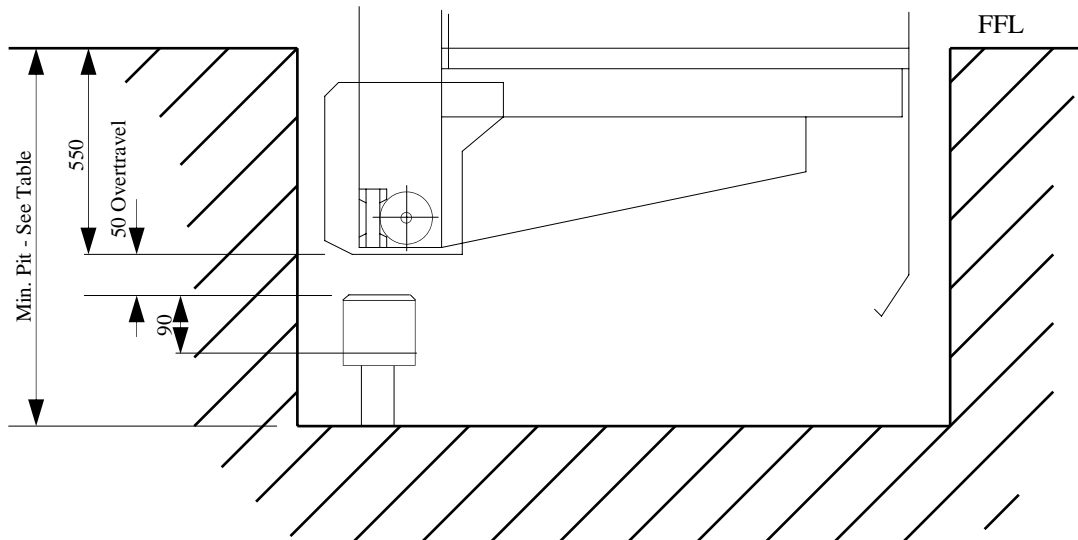

***Note**

A submission to the notified body is required for a design examination certificate for pit depths below EN81-2 minimum pit.

It is the customer's responsibility to seek approval from their Insurers.

A Pit Prop must always be specified

20-D1
17/06/10

Waiver:

This data sheet is for guidance only and must not be used for proper working drawings. Please contact Stannah Lifts for particular details before proceeding. Owing to our policy of continual improvement we reserve the right to alter specifications and dimensions without prior notice.

MAXILIFT

Minimum Pit Depths - MRLi

Stannah

Model	Entrance Type	Sling Type	Standard Pit	Minimum Pit with Design Examination	Minimum Pit EN81-2
8 Person	2PSO Single & Thru.	Direct	1200	990	1200
		Tackle	1200	1055	1200
	2PSO Adjacent	Direct	1200	990	1200
		Tackle	1200	990	1200
	2PCO	Direct	1200	990	1065
Tackle		1200	1040	1070	
10 Person	2PCO	Direct	1200	930	1200
		Tackle	1200	995	1200
13 Person Stretcher	2PSO	Direct	1200	930	1200
		Tackle	1200	995	1200
	2PCO	Direct	1200	930	1065
		Tackle	1200	930	1070
13 Person Commercial	2PCO	Direct	1200	930	1030
		Tackle	1200	930	1070
16 Person	2PCO	Direct	1200	900	1170
		Tackle	1200	980	1170

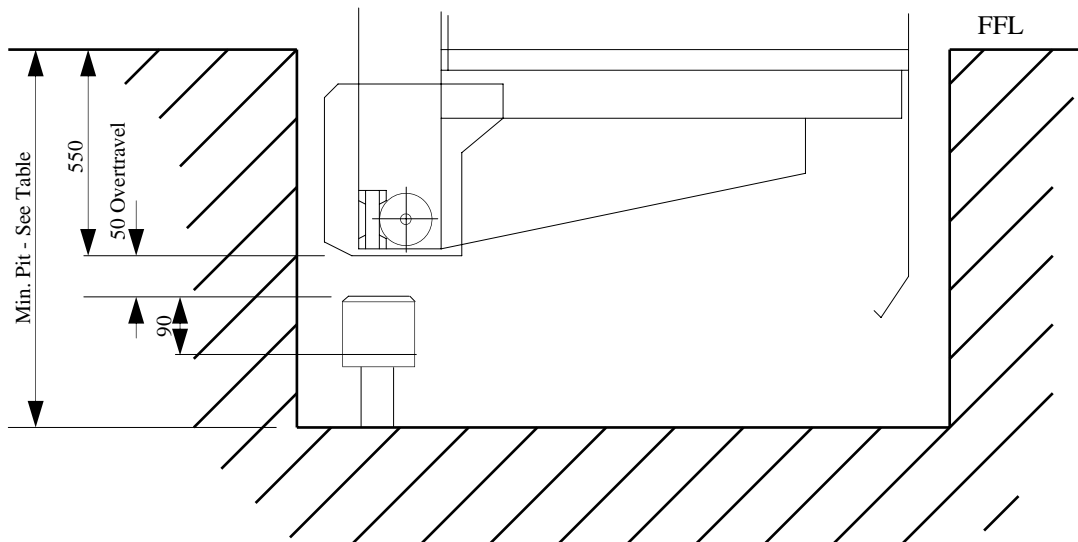

***Note**

A submission to the notified body is required for a design examination certificate for pit depths below EN81-2 minimum pit.

It is the customer's responsibility to seek approval from their Insurers.

A Pit Prop must always be specified

20-D1-1
17/06/10

Waiver:

This data sheet is for guidance only and must not be used for proper working drawings. Please contact Stannah Lifts for particular details before proceeding. Owing to our policy of continual improvement we reserve the right to alter specifications and dimensions without prior notice.

MAXILIFT

Stannah

Minimum Headroom Dimensions

Indirect Acting (2:1)

Headrooms:

Model	Standard Headroom	Min Headroom EN81-2	Min Headroom with Design Examination *
Reduced Headroom range (6 & 8 person)	3200	3200	3050
Maxilift range (6, 8, 10, 13 & 16 person)	3400	3377	3150

*Minimum headrooms require a removable lifting beam.

The lifting beam is removable to permit safer/easier working during initial commissioning/testing of the lift.

The beam does not infringe on the required refuge space.

Once commissioning/testing is complete, the beam should be put back in to position, ready for use by service engineers at a later date.

See table below for details of when a removable lifting beam is required.

Lifting Beam Requirements:

Model	Permanently Installed Lifting Beam	Removable Lifting Beam
Reduced Headroom range (6 & 8 person)	3175 and above	3050 to 3174
Maxilift range (6, 8, 10, 13 & 16 person)	3375 and above	3150 to 3374

All dimensions in mm.

20-D2
24/02/11

Waiver:

This data sheet is for guidance only and must not be used for proper working drawings. Please contact Stannah Lifts for particular details before proceeding. Owing to our policy of continual improvement we reserve the right to alter specifications and dimensions without prior notice.

MAXILIFT

Pit Depth & Headroom Dimensions

Direct Acting (1:1)

Stannah

Lift Travel		Pit Depth	Headroom	EN 81-2 Min. Requirement
Above	Upto & including			
-	① 2700	1100	3200	Reduced Headroom range
2700	2800	1100	3300	
		1200	3200	
2800	② 2900	1100	3400	MaxiLift range
		1200	3300	
		1300	3200	
2900	3000	1100	3500	
		1200	3400	
		1300	3300	
		1400	3200	
3000	3100	1100	3600	
		1200	3500	
		1300	3400	
		1400	3300	
		1500	3200	
3100	3200	1100	3700	
		1200	3600	
		1300	3500	
		1400	3400	
		1500	3300	
		1600	3200	
3200	3300	1200	3700	
		1300	3600	
		1400	3500	
		1500	3400	
		1600	3300	
		1700	3200	
3300	3400	1300	3700	
		1400	3600	
		1500	3500	
		1600	3400	
		1700	3300	
3400	3500	1400	3700	
		1500	3600	
		1600	3500	
		1700	3400	

Important Note

Where the lift travel exceeds that shown in ① or ② the corresponding pit depth and / or headroom dimensions will increase to one of the combinations

Waiver:

This data sheet is for guidance only and must not be used for proper working drawings. Please contact Stannah Lifts for particular details before proceeding. Owing to our policy of continual improvement we reserve the right to alter specifications and dimensions without prior notice.

MAXILIFT

Stannah

Hydraulic Specification 6 Person Maxilift

Tackle 2:1

Type 1008-SL	
Lift Travel (m)	Ram Size dia x wall (mm)
0 - 13.8	100 x 5
13.801 - 16.3	100 x 7.5
16.301 - 18.9	100 x 12

GL = Whilst the duty rating of all lifts should be considered individually, those highlighted must be evaluated to determine the appropriate tank size and possible oil cooler requirement to prevent overheating. Refer to data sheet 20-D31 for guidance.

Specification			Tank Type MRC	Tank Type Motor Room	
Lift Speed (m/s)	Power (HP)	Flow (l/min)	0 - 15.4m	0 - 15.4m	15.401 - 18.9m
0.15	4	35	GL	GL	T2
0.3	8	75	GL	GL	T2
0.4	10.5	100	GL	GL	T2
0.5	13	125	GL	GL	T2
0.63	15	150	GL	GL or T2	T2*
0.86**	25	210	-	T2 or T3	T2 or T3

Direct 1:1

Type 1001-SL	
Lift Travel (m)	Ram Size dia x wall (mm)
0 - 3.5	70 x 5

*A T3 tank cannot be used in this instance. (Min.flow rate = 180l/min)

**All lifts with a T3 tank should use 42mm pipework, with a 1 1/2" rupture valve.

Specification			
Lift Speed (m/s)	Power (HP)	Flow (l/min)	Tank Type
0.15	4	35	GL
0.3	8	75	GL

General

Tank Type	Oil Inlet	Max. Weight (kg)	Size (mm)	
			Width	Depth
GL	1 1/4"	190	750	335
T2	1 1/4"	375	910	560
T3	1 1/2"	660	1060	685

Waiver:

This data sheet is for guidance only and must not be used for proper working drawings. Please contact Stannah Lifts for particular details before proceeding. Owing to our policy of continual improvement we reserve the right to alter specifications and dimensions without prior notice.

MAXILIFT

Stannah

Hydraulic Specification 8 Person Maxilift

Tackle 2:1

Type 1008-SL	
Lift Travel (m)	Ram Size dia x wall (mm)
0 – 12.4	100 x 5
12.401 – 14.7	100 x 7.5
14.701 – 17.1	100 x 12

 = Whilst the duty rating of all lifts should be considered individually, those highlighted must be evaluated to determine the appropriate tank size and possible oil cooler requirement to prevent overheating. Refer to data sheet 20-D31 for guidance.

Specification			Tank Type MRC	Tank Type Motor Room	
Lift Speed (m/s)	Power (HP)	Flow (l/min)	0 – 15.4m	0 – 15.4m	15.401 – 17.1m
0.15	6.5	35	GL	GL	-
0.3	10.5	75	GL	GL	T2
0.4	13	100	GL	GL	T2
0.5	15	125	GL	GL	T2
0.63	20	150	GL	GL or T2	T2*
0.86**	30	210	-	T2 or T3	T2 or T3

*A T3 tank cannot be used in this instance. (Min.flow rate = 180l/min)

Direct 1:1

Type 1001-SL	
Lift Travel (m)	Ram Size dia x wall (mm)
0 – 3.5	80 x 5

**All lifts with a T3 tank should use 42mm pipework, with a 1 1/2" rupture valve.

Specification			
Lift Speed (m/s)	Power (HP)	Flow (l/min)	Tank Type
0.15	4	35	GL
0.3	10.5	100	GL

General

Tank Type	Oil Inlet	Max. Weight (kg)	Size (mm)	
			Width	Depth
GL	1 1/4"	190	750	335
T2	1 1/4"	375	910	560
T3	1 1/2"	660	1060	685

Waiver:

This data sheet is for guidance only and must not be used for proper working drawings. Please contact Stannah Lifts for particular details before proceeding. Owing to our policy of continual improvement we reserve the right to alter specifications and dimensions without prior notice.

MAXILIFT

Stannah

Hydraulic Specification 10 Person Maxilift

Tackle 2:1

Type 1008-SL	
Lift Travel (m)	Ram Size dia x wall (mm)
0 - 13.5	110 x 5
13.501 - 15.9	110 x 7.5
15.901 - 18.7	110 x 12

 = Whilst the duty rating of all lifts should be considered individually, those highlighted must be evaluated to determine the appropriate tank size and possible oil cooler requirement to prevent overheating. Refer to data sheet 20-D31 for guidance.

Specification			Tank Type MRC	Tank Type Motor Room		
Lift Speed (m/s)	Power (HP)	Flow (l/min)	0 - 12.8m	0 - 12.8m	12.801 - 16.5m	16.501 - 18.7m
0.15	6.5	43	GL	GL	-	-
0.3	10.5	75	GL	GL	T2	T2
0.4	15	125	GL	GL	T2	T2
0.5	17	150	GL	GL or T2	T2	T2
0.63	25	180	-	T2 or T3	T2 or T3	T2 or T3
0.86**	30	250	-	T3	T3	T3

Direct 1:1

Type 1001-SL	
Lift Travel (m)	Ram Size dia x wall (mm)
0 - 3.5	90 x 5

**All lifts with a T3 tank should use 42mm pipework, with a 1 1/2" rupture valve.

Specification				
Lift Speed (m/s)	Power (HP)	Flow (l/min)	Tank Type	
0.15	8	75	GL	
0.3	13	125	GL	

General

Tank Type	Oil Inlet	Max. Weight (kg)	Size (mm)	
			Width	Depth
GL	1 1/4"	190	750	335
T2	1 1/4"	375	910	560
T3	1 1/2"	660	1060	685

Waiver:

This data sheet is for guidance only and must not be used for proper working drawings. Please contact Stannah Lifts for particular details before proceeding. Owing to our policy of continual improvement we reserve the right to alter specifications and dimensions without prior notice.

MAXILIFT

Stannah

Hydraulic Specification 13 Person Maxilift

Tackle 2:1

Type 1008	
Lift Travel (m)	Ram Size dia x wall (mm)
0 – 14.2	120 x 5
14.201 – 16.8	120 x 7.5
16.801 – 19.9	120 x 12

= Whilst the duty rating of all lifts should be considered individually, those highlighted must be evaluated to determine the appropriate tank size and possible oil cooler requirement to prevent overheating. Refer to data sheet 20-D31 for guidance.

Specification			Tank Type MRC	Tank Type Motor Room		
Lift Speed (m/s)	Power (HP)	Flow (l/min)	0 – 10.7m	0 – 10.7m	10.701 – 13.8m	13.801 – 19.9m
0.15	6.5	43	GL	GL	-	-
0.3	13	100	GL	GL	T2	T2
0.4	17	150	GL	GL	T2	T2
0.5	25	180	-	T2	T2	T2
0.63	25	210	-	T2 or T3	T2 or T3	T2 or T3
0.86**	40	300	-	T3	T3	T3

Direct 1:1

**All lifts with a T3 tank should use 42mm pipework, with a 1 1/2" rupture valve.

Type 1001-SL	
Lift Travel (m)	Ram Size dia x wall (mm)
0 – 3.5	90 x 5

Specification			
Lift Speed (m/s)	Power (HP)	Flow (l/min)	Tank Type
0.15	8	75	GL
0.3	13	125	GL

General

Tank Type	Oil Inlet	Max. Weight (kg)	Size (mm)	
			Width	Depth
GL	1 1/4"	190	750	335
T2	1 1/4"	375	910	560
T3	1 1/2"	660	1060	685

20-D10
17/06/10

Electrical Requirements by Electrical Contractor Contract No:

Extracts from Stannah Lifts Builders Work Schedule

1. Provide and fit a suitable main switch (lockable in the 'off' position) capable of breaking the supply to the lift on all live conductors. The main switch shall be protected by amp motor rated fuses conforming to BS88 Part 2 Type T or a 'D' Type MCB. Spare set of fuses to be provided. The lift supply shall be: (Delete options not required).

- a. 415V, 3 phase neutral & earth 50 Hz supply terminating in triple pole switch fuse.
- b. 240V, 1 phase neutral & earth 50 Hz supply terminating in single pole switch fuse.
- c. 3 wire 480V, 2 phase neutral & earth 50 Hz supply terminating in double pole switch fuse.

Location of the switch fuse must be adjacent to the entrance of the machine room.

2. The following items are to be connected into a 240V supply, totally independent of the lift supply, terminated in a consumer unit, positioned within machine room. Each fuse (or circuit breaker) to be marked with it's associated circuit protection.

a. Light switch and fluorescent lighting in machine room (to provide at least 200 lux at floor level). Location of the light switch must be within the machine room and adjacent to the entrance.

b. Emergency lighting in machine room (3 hour non-maintained).

c. Spur outlet in machine room fitted with a 5 amp fuse for connecting lift well lighting. Lift well lighting to be 2 way switched between machine room and lift well. Lift well light switch to be positioned within 1 metre of the lowest landing door entrance and mounted on the opposite wall to the lift guides. The switch must be capable of being reached from both the landing floor level and the lift pit floor level. Lift well lighting must be positioned with the light fitting mounted 500mm down from lift well ceiling and 500mm up from lift pit, with intermediate light fittings mounted at a maximum of 4 metre spacing. Light fittings should be polycarbonate bulkhead type and provide at least 50 lux everywhere in the lift well.

d. 13 amp switch sockets in both machine room and pit (for power tools). Switch socket in lift pit to be adjacent to lowest lift well light fitting.

e. Spur outlet in machine room fitted with 5 amp fuse for our engineers to connect the car lighting circuits.

f. Machine room heating and ventilation equipment and thermostats to maintain the temperature in the machine room between 15°C and 30°C.

3. A temporary 110V ac supply for power tools etc., extending the height of the lift well and machine room.

4. Temporary lighting full height of lift well and machine room to lift erectors' requirements.

5. Provide suitable wiring to the machine room and fittings for communication system as outlined on the appropriate data sheets TD 80608 or TD80609.

6. Permanent lighting must be provided outside every lift entrance to ensure a minimum of 50 lux at floor level.

Electrical Current Loadings and Fuse Ratings for Lift Supply Switch Fuse in Machine Room

Strictly Internal Drawing Office Use Only

Note:- Star/Delta starting on motors below 15HP (i.e. as shown in shaded area) are an extra cost option.

		Motor HP	Nominal Start Current	Nominal Run Current	Fuse Rating Motor Rated MCB D Type	Cable Size (mm ²)
415 V 3 phase supply	Direct Starting	3	21	7	10	4.0
		4	27	9	20	4.0
		6.5	36	12	20	4.0
		8	45	15	20	4.0
		10.5	50	17	32	6.0
		13	66	22	32	6.0
	Star/Delta Starting	3	12	7	10	4.0
		4	14	9	20	4.0
		6.5	18	12	20	4.0
		8	22	15	20	4.0
		10.5	25	17	32	6.0
		13	32	22	32	6.0
		15	37	26	32	6.0
		17	42	29	32	6.0
		20	50	34	40	10.0
		25	57	40	50	10.0
		30	70	49	63	16.0
		40	93	64	80	16.0
		240V single phase supply		3	66	22
		4	78	26	32	6.0
240V single phase supply with phase convertor		6.5	108	36	40	10.0
		8	135	45	63	16.0
		10.5	150	51	63	16.0
		13	190	66	80	25.0
480V centre tap neutral supply with phase convertor		6.5	54	18	32	6.0
		8	66	22	32	6.0
		10.5	75	25	32	6.0
		13	96	32	32	6.0

Waiver:

This data sheet is for guidance only and must not be used for proper working drawings. Please contact Stannah Lifts for particular details before proceeding. Owing to our policy of continual improvement we reserve the right to alter specifications and dimensions without prior notice.

MAXILIFT

Stannah

Lift Pit Information

Pit Foothole Details

To be used for guidance only

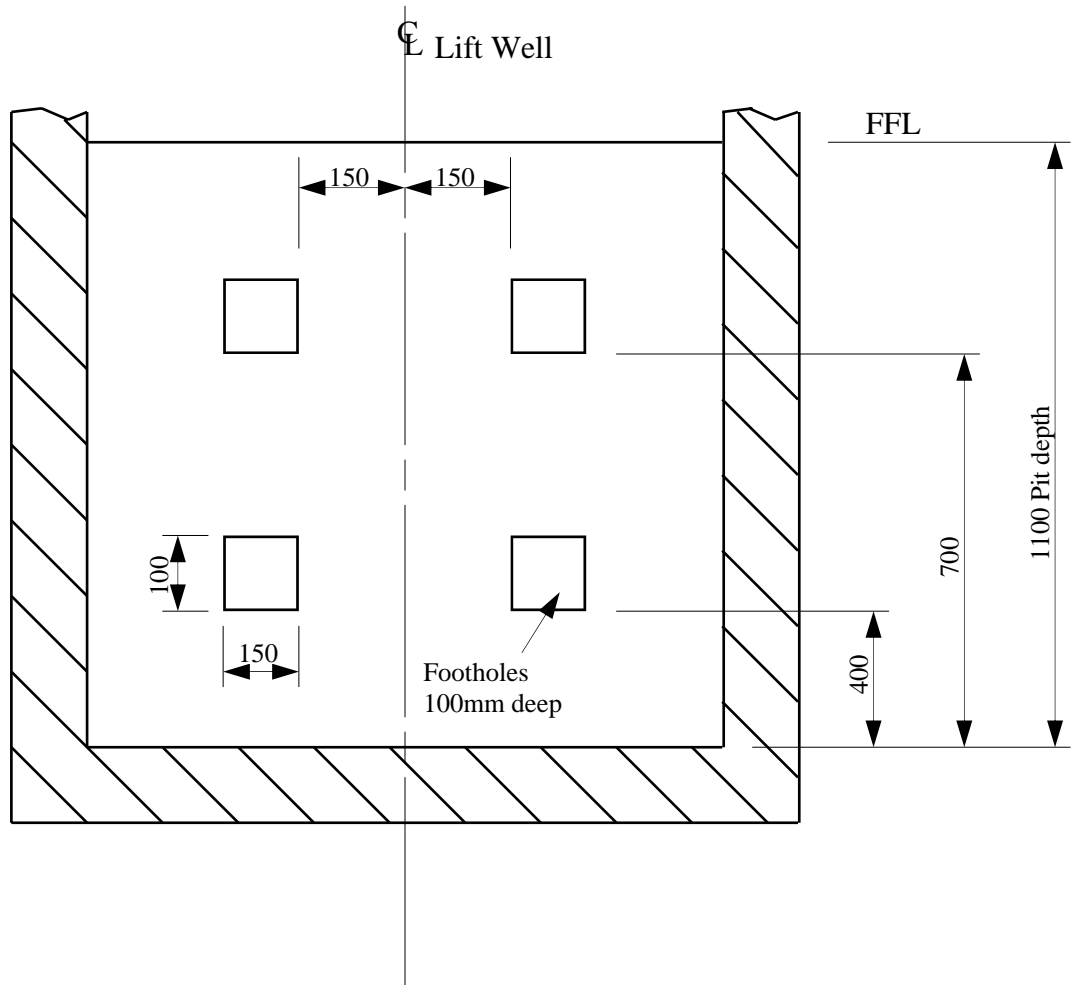

Sectional View Looking at Entrance Wall in Lift Pit.
N.B. Footholes not required on Structure Mounted models

Waiver:

This data sheet is for guidance only and must not be used for proper working drawings. Please contact Stannah Lifts for particular details before proceeding. Owing to our policy of continual improvement we reserve the right to alter specifications and dimensions without prior notice.

MAXILIFT

Stannah

Lift Pit Information

Wall Mounted Models Single Entrance Details

To be used for guidance only

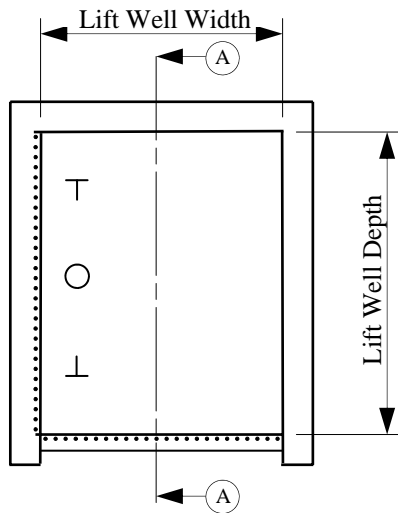

Note:
Left hand slung lift shown
(ram/guide inserts on left).
Reverse handing required
for right hand slung lift.

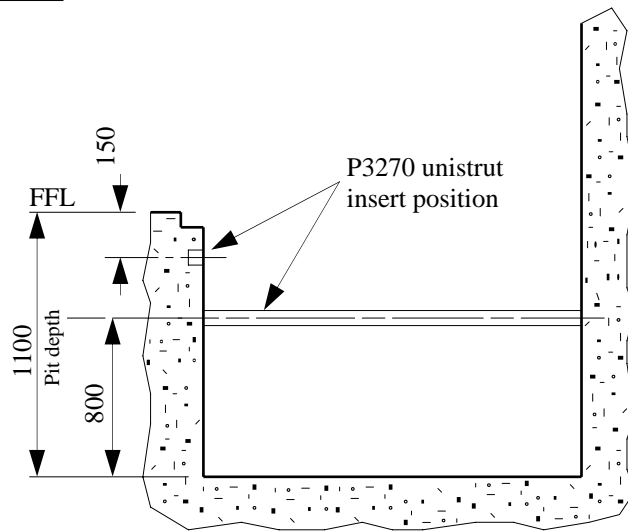

Section A-A

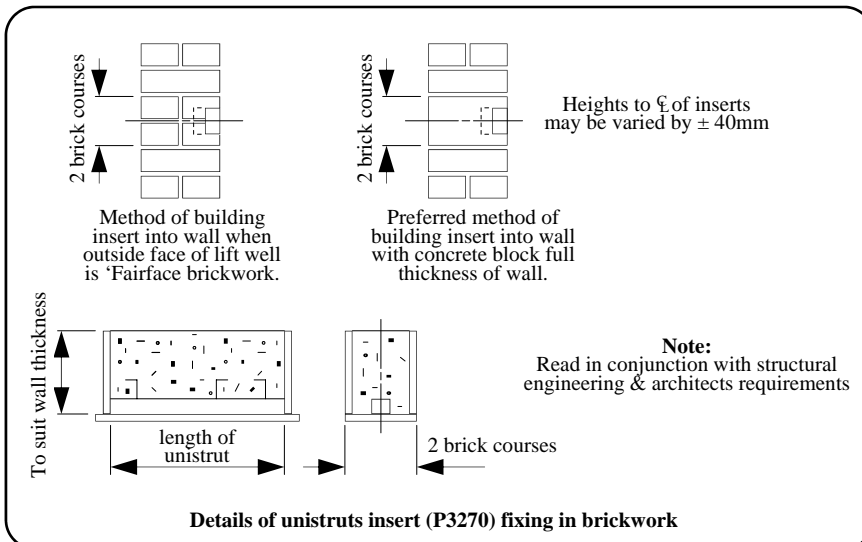

Waiver:

This data sheet is for guidance only and must not be used for proper working drawings. Please contact Stannah Lifts for particular details before proceeding. Owing to our policy of continual improvement we reserve the right to alter specifications and dimensions without prior notice.

MAXILIFT

Stannah

Lift Pit Information

Wall Mounted Models Through Entrance Details

To be used for guidance only

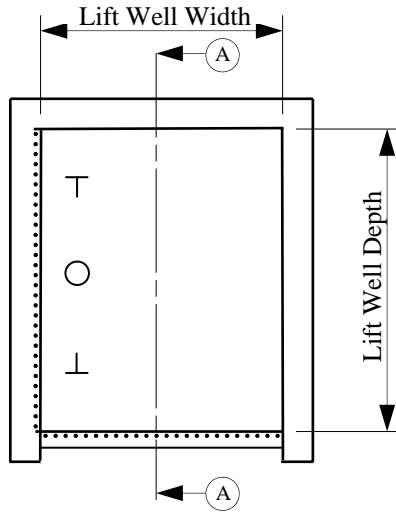

Note:
Left hand slung lift shown (ram/guide inserts on left).
Reverse handing required for right hand slung lift.

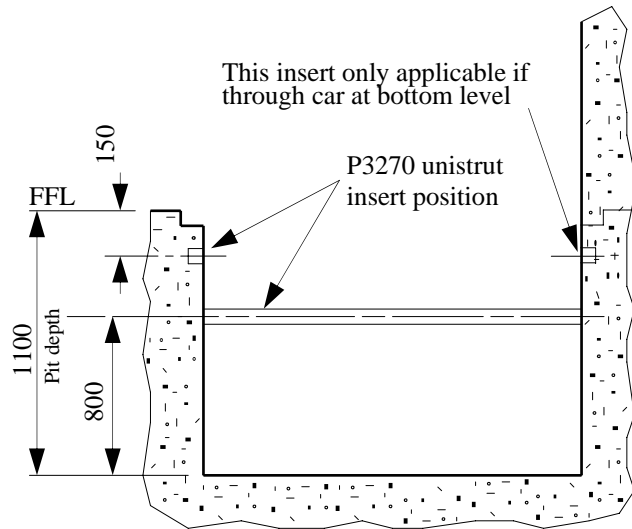

Section A-A

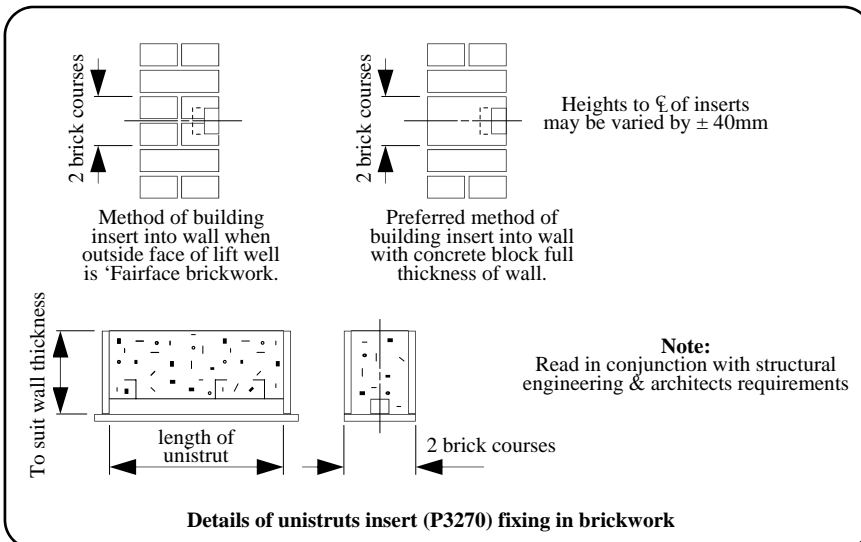

Details of unistrut insert (P3270) fixing in brickwork

Waiver:

This data sheet is for guidance only and must not be used for proper working drawings. Please contact Stannah Lifts for particular details before proceeding. Owing to our policy of continual improvement we reserve the right to alter specifications and dimensions without prior notice.

MAXILIFT

Stannah

Landing Entrance Arrangement

Automatic Two Panel Side Opening (2S)

To be used for guidance only

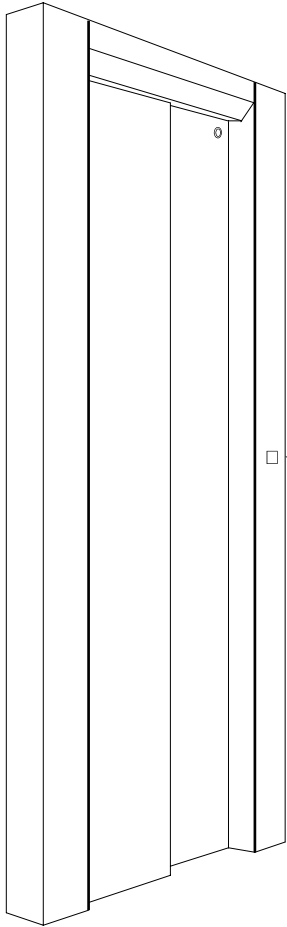

Landing call push

Note
Right hand slam door shown. Reverse handing required for left hand entrance.

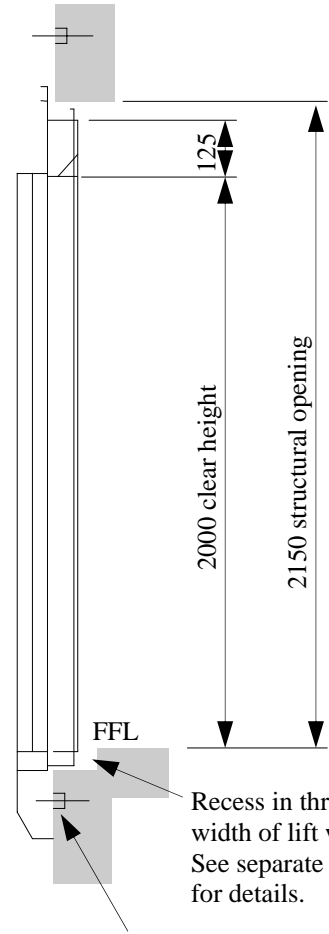

2000 clear height
2150 structural opening

FFL

Recess in threshold full width of lift well. See separate data sheet for details.

See builders work drawing for position of P3270 unistrut inserts, full width of lift well. (NOT required for structure supported models)

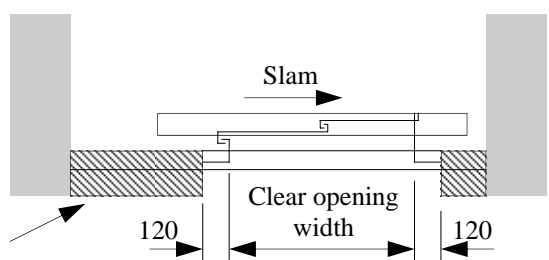

Front walls of lift well to be left down until door frames have been positioned by lift erectors

Waiver:

This data sheet is for guidance only and must not be used for proper working drawings. Please contact Stannah Lifts for particular details before proceeding. Owing to our policy of continual improvement we reserve the right to alter specifications and dimensions without prior notice.

MAXILIFT

Stannah

Landing Entrance Arrangement

Automatic Two Panel Side Opening (2S) MRLi

To be used for guidance only

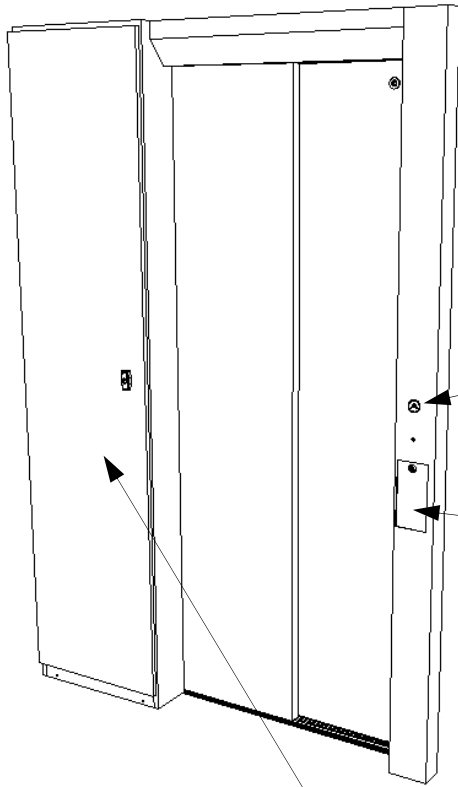

Landing call push

Emergency raising hand pump for use by lift engineers only. Always at lowest floor.

Landing mounted lift controller positioned at any landing

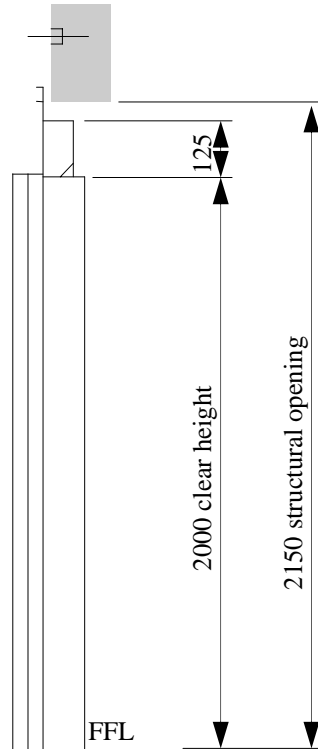

2000 clear height

2150 structural opening

FFL

Recess in threshold full width of lift well. See separate data sheet for details.

See builders work drawing for position of P3270 unistrut inserts, full width of lift well. (NOT required for structure supported models)

Note

Right hand slam door shown. Reverse handing required for left hand entrance.

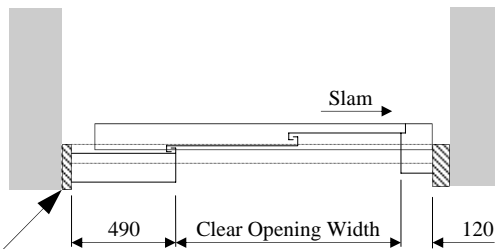

Front walls of lift well to be left down until door frames have been installed

Machine Room-Less
MRLi
20-D17-2
17/06/10

Waiver:

This data sheet is for guidance only and must not be used for proper working drawings. Please contact Stannah Lifts for particular details before proceeding. Owing to our policy of continual improvement we reserve the right to alter specifications and dimensions without prior notice.

MAXILIFT

Stannah

Landing Entrance Arrangement

Automatic Two Panel Centre Opening (2C)

To be used for guidance only

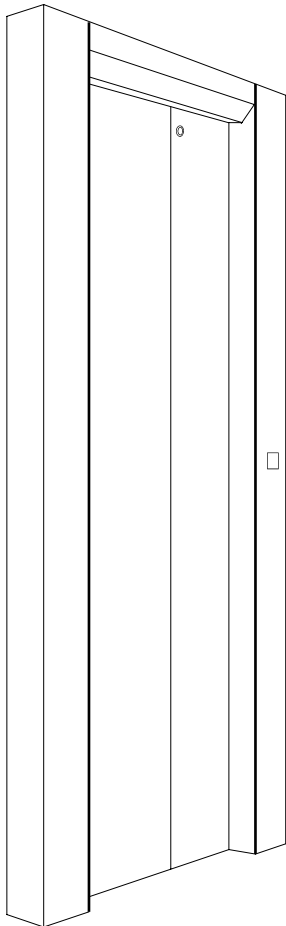

Landing
call push

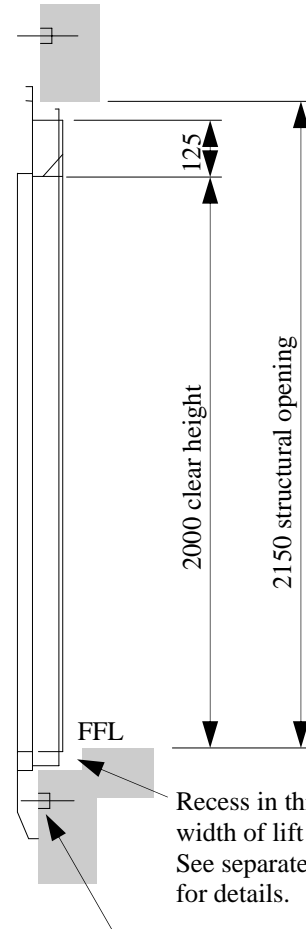

See builders work drawing for position of P3270 unistrut inserts, full width of lift well. (NOT required for structure supported models)

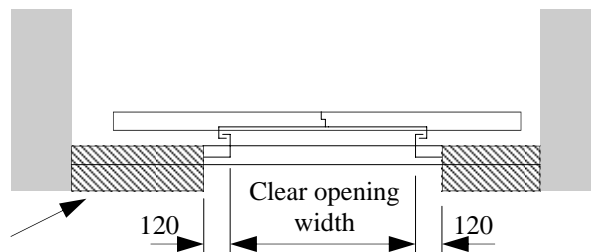

Front walls of lift well to be left down until door frames have been positioned by lift erectors

Waiver:

This data sheet is for guidance only and must not be used for proper working drawings. Please contact Stannah Lifts for particular details before proceeding. Owing to our policy of continual improvement we reserve the right to alter specifications and dimensions without prior notice.

MAXILIFT

Stannah

Landing Entrance Arrangement

Automatic Two Panel Centre Opening (2C) MRLi

To be used for guidance only

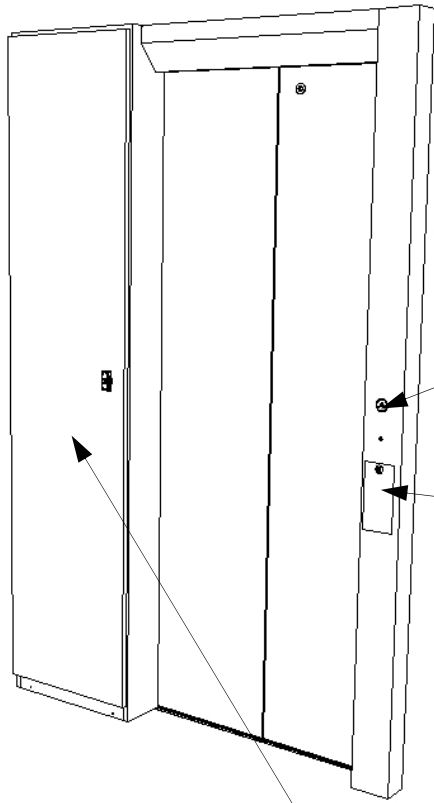

Landing call push

Emergency raising hand pump
for use by lift engineers only.
Always at lowest floor.

Landing mounted lift controller
positioned at any landing

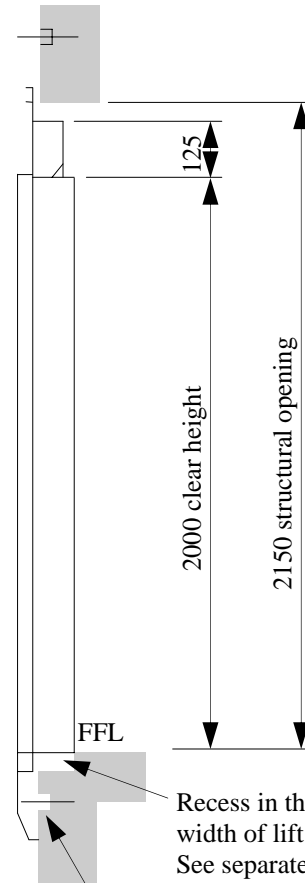

2000 clear height

2150 structural opening

FFL

Recess in threshold full
width of lift well.
See separate data sheet
for details.

See builders work drawing
for position of P3270 unistrut
inserts, full width of lift well.
(NOT required for structure
supported models)

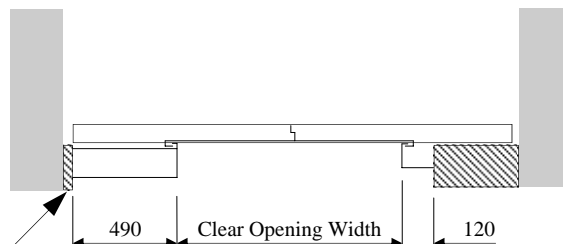

490 Clear Opening Width 120

Front walls of lift well to be
left down until door frames
have been installed

Machine Room-Less
MRLi
20-D18-1
17/06/10

Waiver:

This data sheet is for guidance only and must not be used for proper working drawings. Please contact Stannah Lifts for particular details before proceeding. Owing to our policy of continual improvement we reserve the right to alter specifications and dimensions without prior notice.

MAXILIFT

Stannah

Machine Room-Less Builders Work - Electrical Requirements Electrical Wiring Detail for MRC-SM or MRC-RM 8 Person Maxilift

Termination - Option A

Where the lift machine cabinet is installed in an area with public access, the lift supplies must be terminated directly within the cabinet to avoid the need for any external visible equipment. Armoured cables can be terminated within the cabinet into a suitable 'metal box' (mounted on the back wall 1700mm above FFL and max depth 100mm) so that the glands can be made good. Please ensure that the earth is correctly terminated to the cabinet earth rail.

Telephone requirements

Tamperproof socket for dedicated telephone exchange line for Lift Auto Dial System. To be positioned within 0.5m of lift machine cabinet.

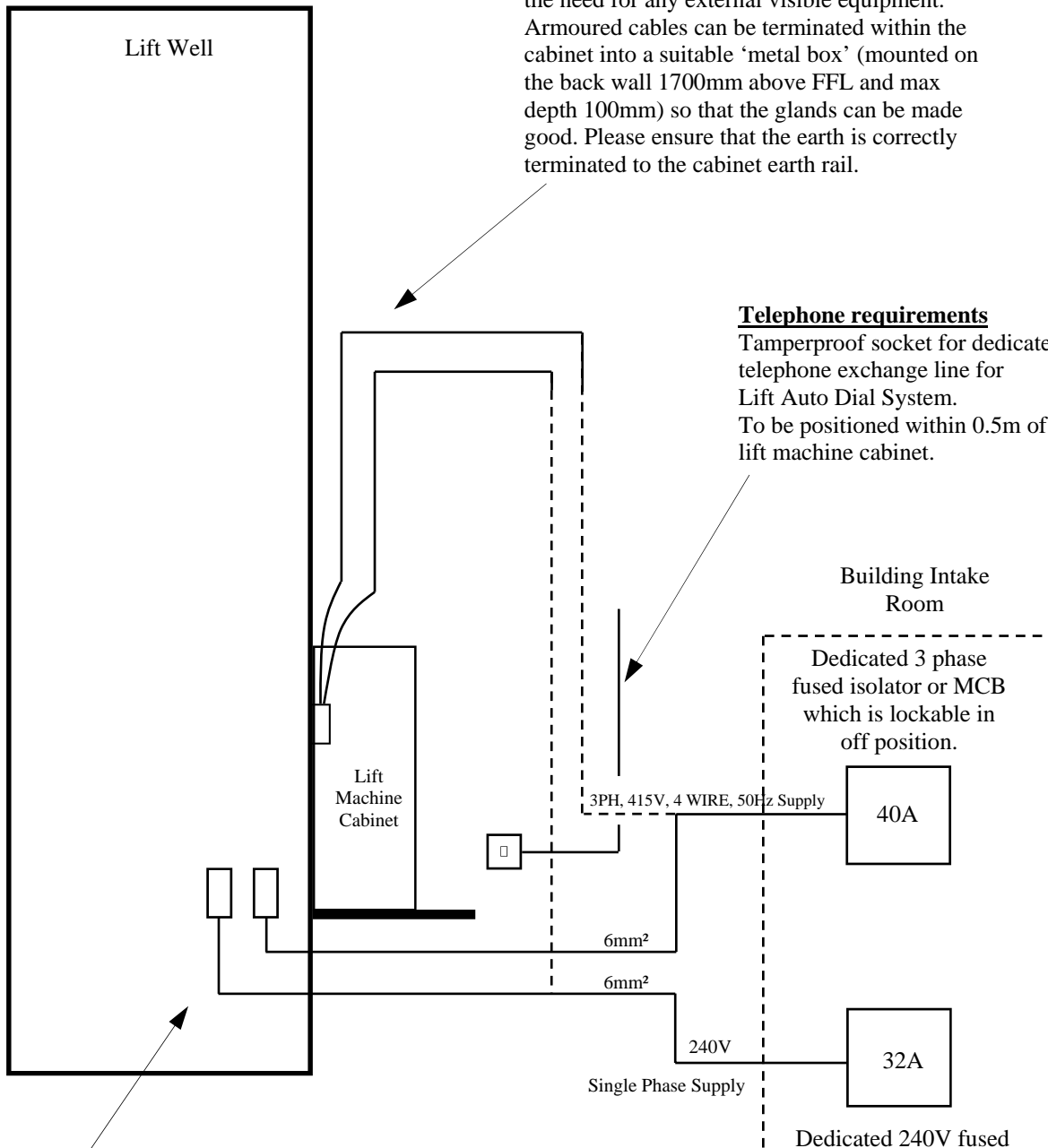

Termination - Option B

Where the lift machine cabinet is installed in a lockable room away from public access, the preferred termination is into 2, suitably sized isolators or termination boxes, where the lift installer can run the joining cables through conduit into the cabinet.

Power Supply Requirements

MAXILIFT

MRC Electrical Capabilities

Stannah

Motor Starting	Call System	Option A	Option B	Max No. of Floors	Sequential Door Operation	Accept
Delta	SBC	Voicebox	Aux Doors	5	Yes	✓
Delta	HCDC / LCUC	Voicebox	Aux Doors	5	Yes	✓
Delta	FDC	Voicebox	Aux Doors	5	No	✓
Delta	FDC	Voicebox	Aux Doors	5	Yes	Requires checking
Star/Delta	SBC	Voicebox	Aux Doors	5	Yes	✓
Star/Delta	HCDC / LCUC	Voicebox	Aux Doors	5	Yes	✓
Star/Delta	FDC	Voicebox	* No	5	No	✓
Star/Delta	FDC	* No	Aux Doors	5	No	✓
Star/Delta	FDC	Voicebox	Aux Doors	5	No	Requires checking
Star/Delta	FDC	Voicebox	Aux Doors	5	Yes	Requires checking

* *Less floors will still not make this possible*

- Optional Fire Evacuation and Sabbath control can be reviewed per job.
- Phase converters are not available on MRC units.

Electrical Requirements by Electrical Contractor

Contract No:

Extracts from Stannah Lifts Builders Work Schedule for MRC

1. Provide and fit a permanent 4 wire 415V, 3 phase, neutral and earth, 50Hz supply terminating in a suitable main switch (lockable in the 'off' position) capable of breaking the supply on all live conductors at the buildings intake room clearly labelled 'Lift Main Supply'. The main switch shall be protected by 40 amp motor rated device* capable of interrupting the start current.

It is essential that a supply is available for installation commencement. Where a permanent supply is not ready a temporary supply will be acceptable. NOTE: A PERMANENT SUPPLY MUST BE AVAILABLE FOR FINAL TESTING OF LIFT.

*If an isolator is used, it should be fitted with 'motor rated' HRC fuses. A spare set of fuses should be provided.

*If an MCB is used it should be fitted with a type 'D' cartridge.

2. 240V independent, single phase 32 amp supply protected by a fused isolator or MCB, both must be lockable in the 'off' position at the building intake room clearly labelled 'Lift Service Supply'.
3. Suitable cables from items 1 and 2 are to be run in one of the following ways to the lift machine cabinet location:-
 - a) 1 phase and 3 phase lift supplies to be run to a position directly above the lift machine room cabinet with 5 metres of spare cable coiled up for Stannah to connect into the cabinet. Once connected, builder to test and certify the supply of the lift machine room cabinet in accordance with current regulations.
 - b) 1 phase and 3 phase lift supplies to terminate in suitable switch isolators located in the lift well at a level adjacent to the lift machine cabinet. Both isolators to be lockable in the 'off' position.
4. Suitable heating and/or ventilation equipment and thermostats to maintain the temperature in the machine cabinet location between 15°C and 30°C.
5. Emergency lighting to the lift machine cabinet location (3 hour minimum).
6. Exclusive telephone exchange line with a tamper proof (BT. NTE5B typical) socket or equivalent for car rescue communication unit terminated adjacent to the lift machine cabinet.
7. Lift Well:
A temporary 110V AC supply for power tools etc extended to the height of the well and machine cabinet location.
8. Provide suitable temporary task lighting the height of the well and at the machine room cabinet location.

Electrical Current Loadings and Fuse Ratings for Lift Supply for MRC

Strictly Internal Drawing Office Use Only

Note:- Star/Delta starting on motors below 15HP (i.e. as shown in shaded area) are an extra cost option.

		Motor HP	Nominal Start Current	Nominal Run Current	Fuse Rating Motor Rated MCB D Type	Cable Size (mm ²)
415 V 3 phase supply	Direct Starting	3	21	7	32	4.0
		4	27	9	32	4.0
		6.5	36	12	32	4.0
		8	45	15	32	4.0
		10.5	50	17	32	4.0
		13	66	22	32	4.0
	Star/Delta Starting	3	12	7	32	4.0
		4	14	9	32	4.0
		6.5	18	12	32	4.0
		8	22	15	32	4.0
		10.5	25	17	32	4.0
		13	32	22	32	4.0
		15	37	26	32	4.0
		17	42	29	32	6.0
20	50	34	40	10.0		

Maxilift Noise Levels

Drive Housing/ Reading Location		Speed m/s	Noise level @ 1 metre (dBA)						Contactors
			0.3		0.5		0.63		
			Up	Down	Up	Down	Up	Down	
MRC		Empty	60	50			67	63	67
		1/2 load	60	65			63	61	
		Full load	61	68			66	69	
Motor Room	Inside motor room	Empty			71	68			62
		1/2 load			71	70			
		Full load			71	73			
	Outside motor room	Empty			55	49			<40
		1/2 load			55	50			<40
		Full load			56	53			<40
MRLi	Inside lift car	Full Load			65	55			
	At lowest landing	Full Load			52	55			

 = Not measured to date.

The above tabulation is based on 8 person lifts with the following specification-

Motor room & MRC

0.3m/s = 8HP, 75 l/min

0.5m/s = 17HP, 150 l/min

0.63m/s = 17HP, 150 l/min

MRLi

0.5m/s = 13HP, 150l/min

Noise when the lift travels up is airborne noise and structurally transmitted noise.

Noise when the lift travels down is airborne noise only.

Waiver:

This data sheet is for guidance only and must not be used for proper working drawings. Please contact Stannah Lifts for particular details before proceeding. Owing to our policy of continual improvement we reserve the right to alter specifications and dimensions without prior notice.

MAXILIFT

Stannah

Machine Room-Less MRC Oil Cooler Option

*To be used for guidance only - specific details
May be found on Stannah Lifts Builder's Work Drawings*

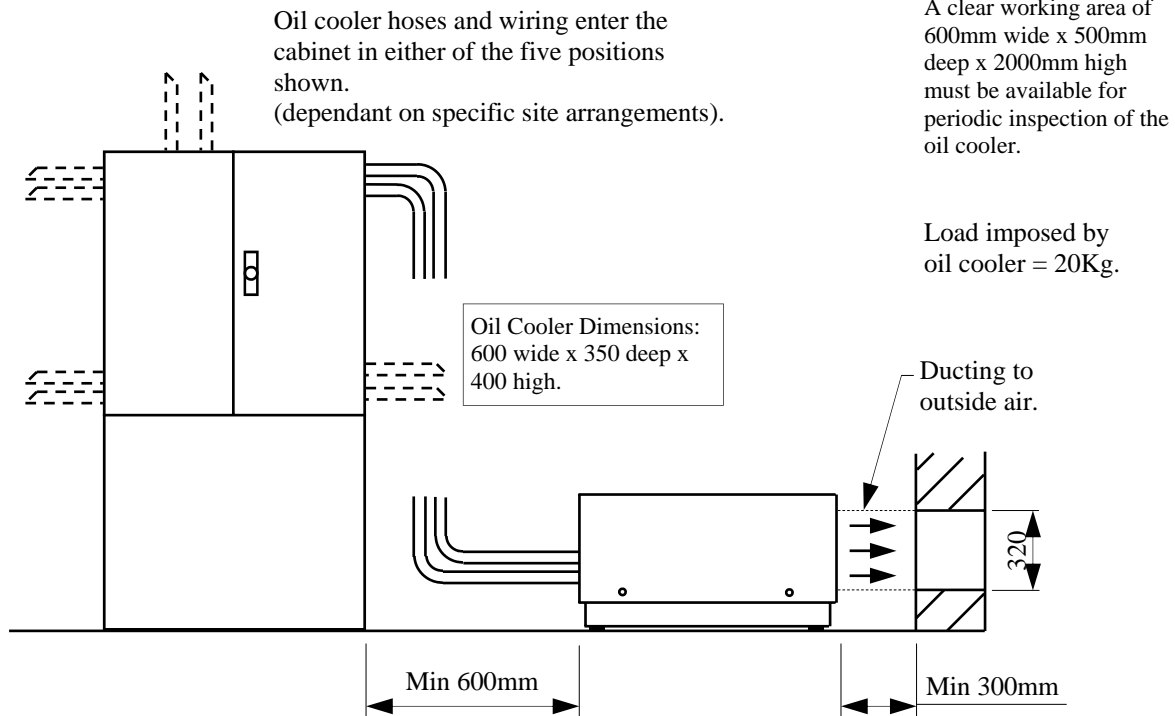

Position: Ideally the oil cooler should be positioned in close proximity to the lift machine cabinet to minimise hose and wiring runs (maximum horizontal distance 9m). The oil cooler can be mounted inside or outside, preferably outside.

Ducting: Builder to provide ducting between the oil cooler and lift machine cabinet for oil cooler hoses and wiring. When the oil cooler is mounted inside, hot exhaust air must be ducted to outside air by the builder to maintain the temperature in the vicinity of the cabinet and oil cooler between 15 and 30°C. A thermostatically controlled chiller may be required in exceptional circumstances to achieve this. Outlet from heat exchanger ducting = Ø320mm.

Supply: A 415V 3 phase neutral and earth 50 Hz supply is required. This supply should be terminated in either a suitable triple pole fused isolator or MCB at the building intake room clearly labelled "Lift Oil Cooler Supply". The supply must be capable of being locked in the "off" position. Fuse protection to be rated at 10 amps. Cables from the isolator or MCB are to be run in one of the following ways to the lift machine cabinet location:

- a. 3 phase oil cooler supply to be run to a position directly above the lift machine cabinet with 5 metres of spare cable coiled up for Stannah to connect into the top of the cabinet. Once connected, builder to test and certify the supply to the lift machine cabinet in accordance with current Regulations.

OR

- b. 3 phase supply to terminate in suitable switch isolator located in lift well at the level adjacent to the lift machine cabinet. Isolator to be lockable in the 'off' position.

Lighting: Permanent lighting at a level of 200 lux is required in the location of the oil cooler.

Noise: The oil cooler produces airborne noise at a level of 70 dBA at 1m.

Access: Access to the oil cooler location must be safe in all circumstances without necessitating entry into private premises

20-D30
17/06/10

Waiver:

This data sheet is for guidance only and must not be used for proper working drawings. Please contact Stannah Lifts for particular details before proceeding. Owing to our policy of continual improvement we reserve the right to alter specifications and dimensions without prior notice.

MAXILIFT

Stannah

Maxilift - Hydraulics Selection

This document should provide a good basis for the hydraulic requirements of a Maxilift. However it is not definitive and should only be used for guidance.

The duty cycle of a hydraulic lift is dependant on various criteria; this includes load, lift travel, passenger traffic conditions and lift speed.

The charts shown here are intended to help quantify the use of a specific lift. The accuracy of the final hydraulic requirement is largely dependant on the value used for the number of persons in the car.

The following values are intended to provide guidance on likely load conditions in different environments.

- Retail use approx
100% of rated load

- Leisure/colleges/hotels use
approx 75% of rated load

- Offices/Large flats use
approx 50% of rated load

- Nursing homes, small flats etc use
approx 25% of rated load

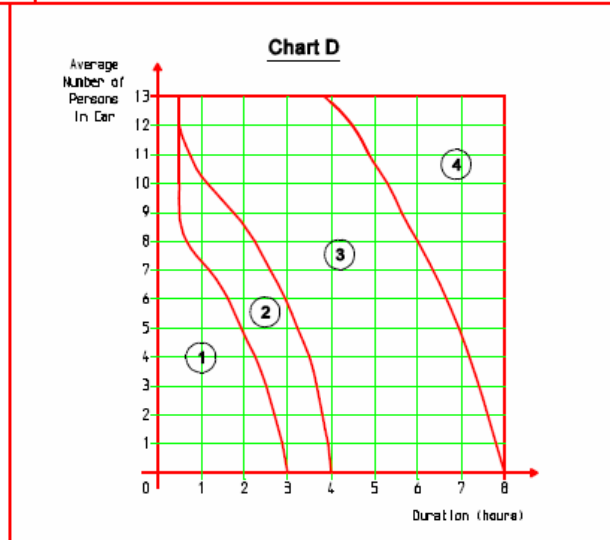
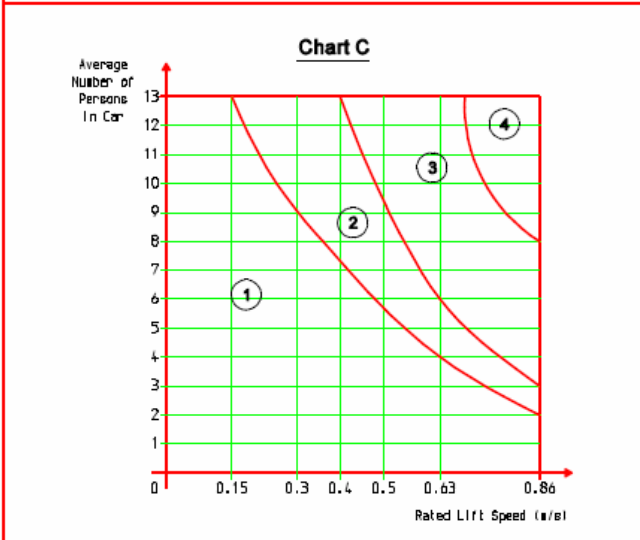
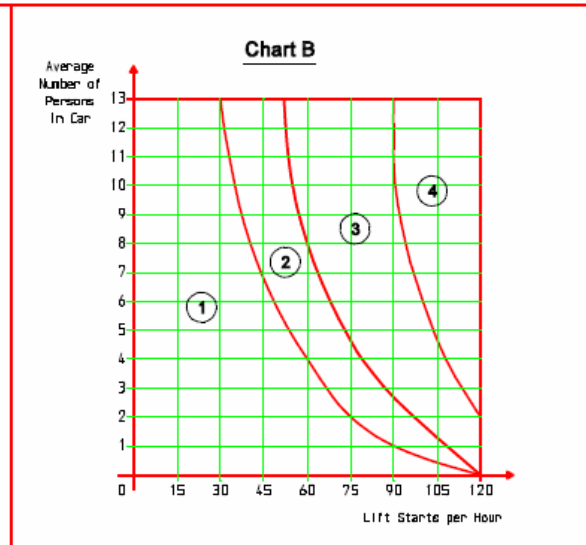
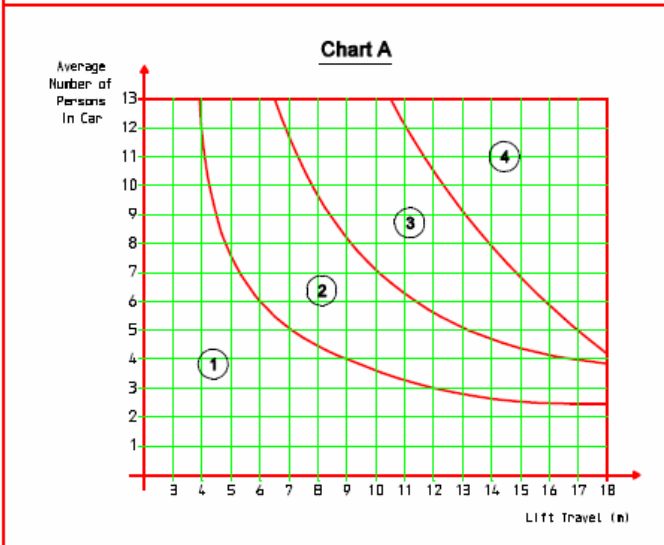

Quantifying the Hydraulic Requirement

- Establish the :
 - average number of persons expected to be in car
 - lift travel
 - required lift starts per hour
 - rated lift speed
- Use these quantities to obtain a value from each of Charts A, B, C and D
- Add the four values together, and use the table to determine the hydraulic requirements

A+B+C+D	Requirement
4 to 6	Standard hydraulics
7 or 8	May need an oil cooler or larger tank
9 to 13	Oil cooler required
14 to 16	Not possible

If a total of 7 or 8 is obtained, traffic conditions must be considered.
 Are busy peak periods expected?
 Will the lift be in use continuously, or just for periods of an hour or so?
 Will heavy goods be transported in the lift?

Waiver:

This data sheet is for guidance only and must not be used for proper working drawings. Please contact Stannah Lifts for particular details before proceeding. Owing to our policy of continual improvement we reserve the right to alter specifications and dimensions without prior notice.

MAXILIFT

Stannah

Hydraulic Specification 8 Person Maxilift

Machine Room-Less : MRLi

Tackle 2:1

Type 1008-SL	
Lift Travel (m)	Ram Size dia x wall (mm)
0 – 12.4	100 x 5
12.401 – 14.7	100 x 7.5
14.701 – 17.1	100 x 12

Specification		
Lift Speed (m/s)	Power (HP)	Flow (l/min)
0.3	8	75
0.4	10.5	100
0.5	13	125
0.63	15	150

Direct 1:1

Type 1001-SL	
Lift Travel (m)	Ram Size dia x wall (mm)
0 – 3.5	80 x 5

Specification		
Lift Speed (m/s)	Power (HP)	Flow (l/min)
0.3	8	100
0.4	10.5	125
0.5	15	150

General

Tank Type	Oil Inlet	Max. Weight (kg)	Size (mm)	
			Width	Depth
MRL/NGV	1 ¼"	235	1200	350

Machine Room-Less
MRLi
20-D32
24/02/11

Waiver:

This data sheet is for guidance only and must not be used for proper working drawings. Please contact Stannah Lifts for particular details before proceeding. Owing to our policy of continual improvement we reserve the right to alter specifications and dimensions without prior notice.

MAXILIFT

Stannah

Hydraulic Specification 10 Person Maxilift

Machine Room-Less : MRLi

Tackle 2:1

Type 1008-SL	
Lift Travel (m)	Ram Size dia x wall (mm)
0 – 13.6	110 x 5
13.601 – 14.8	110 x 7.5

Specification		
Lift Speed (m/s)	Power (HP)	Flow (l/min)
0.3	10.5	100
0.4	13	125
0.5	15	150
0.63	17	180

Direct 1:1

Type 1001-SL	
Lift Travel (m)	Ram Size dia x wall (mm)
0 – 3.5	90 x 5

Specification		
Lift Speed (m/s)	Power (HP)	Flow (l/min)
0.3	10.5	125
0.4	13	180

General

Tank Type	Oil Inlet	Max. Weight (kg)	Size (mm)	
			Width	Depth
MRL/NGV	1 ¼"	235	1200	350

Machine Room-Less
MRLi
20-D33
24/02/11

Waiver:

This data sheet is for guidance only and must not be used for proper working drawings. Please contact Stannah Lifts for particular details before proceeding. Owing to our policy of continual improvement we reserve the right to alter specifications and dimensions without prior notice.

MAXILIFT

Stannah

Hydraulic Specification 13 Person Maxilift

Machine Room-Less : MRLi

Tackle 2:1

Type 1008	
Lift Travel (m)	Ram Size dia x wall (mm)
0 – 12.3	120 x 5

Specification		
Lift Speed (m/s)	Power (HP)	Flow (l/min)
0.3	10.5	100
0.4	15	150
0.5	17	180

Direct 1:1

Type 1001-SL	
Lift Travel (m)	Ram Size dia x wall (mm)
0 – 3.5	90 x 5

Specification		
Lift Speed (m/s)	Power (HP)	Flow (l/min)
0.3	10.5	125
0.4	15	180

General

Tank Type	Oil Inlet	Max. Weight (kg)	Size (mm)	
			Width	Depth
MRL/NGV	1 ¼"	235	1200	350

Machine Room-Less
MRLi
20-D34
24/02/11

This data sheet is for guidance only and must not be used for proper working drawings. Please contact Stannah Lifts for particular details before proceeding. We reserve our policy of continual improvement and we reserve the right to alter specifications and dimensions without prior notice.

MAXILIFT

Stannah

Landing Entrance Cut-Out Details

Note - For an entrance fitted with an MRL landing controller see data sheet 20-D37

Model Reference	Plan View	Car & Landing Door Type	Entrance Arrangement	Wall Mounted	Structure Supported	Lintel (above entrance) cut-out size*	Threshold cut-out size	† Minimum ffl to ffl (mm)
P6, M6 P8, M8 M13-1		Ⓢ Auto 2 panel side opening	Single Entry & Through Car	WM	-	not req'd		2565
P6, M6 P8, M8		Ⓢ Auto 2 panel side opening	Single Entry & Through Car	-	SS	not req'd		2565
P8, M8		Ⓢ Auto 2 panel side opening	Adjacent Entry	WM	-	not req'd		2565
P8, M8		Ⓢ Auto 2 panel side opening	Adjacent Entry	-	SS	not req'd		2565
P8, M8 M10, M13-1 M13-2, M16		Ⓢ Auto 2 panel centre opening	Single Entry & Through Car	WM	-	not req'd		2565
P8, M8		Ⓢ Auto 2 panel centre opening	Single Entry & Through Car	-	SS	not req'd		2565

†Note - Reduced dimensions may be achievable on a special basis. Please consult the drawing office for details.

*Note - Reduced shaft depths can be achieved if lintel rebates are incorporated. Please contact Stannah for details.







This data sheet is for guidance only and must not be used for proper working drawings. Please contact Stannah Lifts for particular details before proceeding. Our policy of continual improvement we reserve the right to alter specifications and dimensions without prior notice.

MAXILIFT

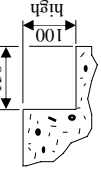
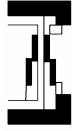
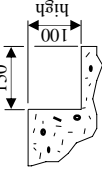
Stannah

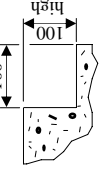
MRL Landing Entrance Cut-Out Details (with Entrance Controller)

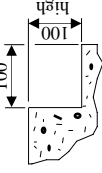
Note - The information relates to entrances fitted with the MRL Entrance Controller. For all other entrances see data sheet 20-D35

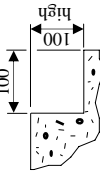
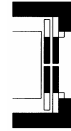
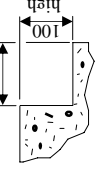
Model Reference	Plan View	Car & Landing Door Type	Entrance Arrangement	Wall Mounted	Structure Supported	Lintel (above entrance) cut-out size*	Threshold cut-out size	† Minimum ffl to ffl (mm)
P8, M8 M13-1		Ⓢ Auto 2 panel side opening	Single Entry & Through Car	WM	-	not req'd		2565
P8, M8		Ⓢ Auto 2 panel side opening	Single Entry & Through Car	-	SS	not req'd		2565
P8, M8		Ⓢ Auto 2 panel side opening	Adjacent Entry	WM	-	not req'd		2565
P8, M8		Ⓢ Auto 2 panel side opening	Adjacent Entry	-	SS	not req'd		2565
P8, M8 M10, M13-1 M13-2, M16		Ⓢ Auto 2 panel centre opening	Single Entry & Through Car	WM	-	not req'd		2565
P8, M8		Ⓢ Auto 2 panel centre opening	Single Entry & Through Car	-	SS	not req'd		2565

†Note - Dimensions apply to the floor below on MRLi models and are absolute. For all other entrances see data sheet 20-D35.

*Note - Reduced shaft depths can be achieved if lintel rebates are incorporated. Please contact Stannah for details.

Waiver:

This data sheet is for guidance only and must not be used for proper working drawings. Please contact Stannah Lifts for particular details before proceeding. Owing to our policy of continual improvement we reserve the right to alter specifications and dimensions without prior notice.

MAXILIFT

Stannah

Hydraulic Specification 16 Person Maxilift

Tackle 2:1

Type 1008	
Lift Travel (m)	Ram Size dia x wall (mm)
0 – 16.2	140 x 5
16.201 – 19.1	140 x 7.5

 = Whilst the duty rating of all lifts should be considered individually, those highlighted must be evaluated to determine the appropriate tank size and possible oil cooler requirement to prevent overheating. Refer to data sheet 20-D31 for guidance.

Specification			Tank Type MRC	Tank Type Motor Room		
Lift Speed (m/s)	Power (HP)	Flow (l/min)	0 – 7.8m	0 – 7.8m	7.801 – 16.6m	16.601 – 19.1m
0.3	15	150	GL	GL	T2	-
0.4	20	180	-	GL or T2	T2	T3
0.5	30	250	-	T3	T3	T3
0.63	40	300	-	T3	T3	T3
0.86**	50	430	-	T3	T3	T3

Direct 1:1

Type 1001-SL	
Lift Travel (m)	Ram Size dia x wall (mm)
0 – 3.5	100 x 5

**All lifts with a T3 tank should use 42mm pipework, with a 1 1/2" rupture valve.

Specification			
Lift Speed (m/s)	Power (HP)	Flow (l/min)	Tank Type
0.3	15	150	GL
0.4	20	180	T2
0.5	30	250	T3

General

Tank Type	Oil Inlet	Max. Weight (kg)	Size (mm)	
			Width	Depth
GL	1 1/4"	190	750	335
T2	1 1/4"	375	910	560
T3	1 1/2"	660	1060	685

Waiver:

This data sheet is for guidance only and must not be used for proper working drawings. Please contact Stannah Lifts for particular details before proceeding. Owing to our policy of continual improvement we reserve the right to alter specifications and dimensions without prior notice.

MAXILIFT

Stannah

Hydraulic Specification 16 Person Maxilift

Machine Room-Less : MRLi

Tackle 2:1

	Type 1008
Lift Travel (m)	Ram Size dia x wall (mm)
0 – 9.0	140 x 5

Specification		
Lift Speed (m/s)	Power (HP)	Flow (l/min)
0.3	15	150
0.4	15	180

Direct 1:1

	Type 1001-SL
Lift Travel (m)	Ram Size dia x wall (mm)
0 – 3.5	100 x 5

Specification		
Lift Speed (m/s)	Power (HP)	Flow (l/min)
0.3	15	150
0.4	15	180

General

Tank Type	Oil Inlet	Max. Weight (kg)	Size (mm)	
			Width	Depth
MRL/NGV	1 ¼"	235	1200	350

Machine Room-Less
MRLi
20-D39
24/02/11



Stannah Lifts Limited
Anton Mill, Andover, Hampshire, SP10 2NX

Tel : 01264 339090
Fax : 01264 337942